

*WPT 480/P*  
*WPT 600/P*  
*WPT 720/P*

---

**Owner's Record**

**Date of Purchase:** \_\_\_\_\_

**Purchased from:** \_\_\_\_\_

**Model:** \_\_\_\_\_

**Serial Number:** \_\_\_\_\_

**National Vacuum Equipment, Inc.**

© 1998 National Vacuum Equipment, Inc.

11/98

No part of this manual may be reproduced without the written permission of National Vacuum Equipment, Inc.

# Contents

---

## **Introduction**

About National Vacuum Equipment, Inc.	5
---------------------------------------	---

## **Limited Warranty**

Warranty	7
Warranty Procedures	9

## **The WPT/P Series Pumps**

Pump Specifications	11
Performance	12
System requirements	13

## **Operating Instructions**

Installation	15
Automatic oil pump	16
Adjusting the automatic oil pump	16
Recommended lubrication	17
Normal operation for liquid cooled pumps:	18
Maintenance	19
Determining the rotation of the pump	19

## **WPT Pump Cooling System**

WPT Pump Cooling System	20
-------------------------	----

## **Troubleshooting**

Pump overheats	21
Too much oil use	21
Pump doesn't turn	22
No vacuum or pressure in tank	22

## **Pump Rebuilding**

Complete rebuild	23
------------------	----

*Table of Contents continues on next page.*

## **Parts List - WPT Series Pumps**

Parts Diagram	34
Parts List	35

## **Four-Way Valve Assembly**

Four-Way Valve Diagram and Parts List	37
---------------------------------------	----

## **Lubrication/Cooling Systems**

WPT 480/P-WPT 600/P-WPT 720/P	38
WPT 480/PW-WPT 600/PW-WPT 720/PW	39
Lubrication/Cooling System Parts	40
Automatic Oil Pumps <sup>3-4</sup>	43

## **Index**

# Introduction

*General Information*

# NVE

---

## About National Vacuum Equipment, Inc.



Congratulations! You now own a quality vacuum/pressure pump exclusively distributed in North America by National Vacuum Equipment, Inc. You have not only acquired a superior piece of equipment from a qualified dealer, you have hired a team of vacuum experts. We stand ready to work with your dealer to answer your questions and provide you with the information necessary to keep your equipment in peak working condition.

Thank you for using National Vacuum Equipment.

### **OUR MISSION:**

We are dedicated to the manufacture and wholesale distribution of quality vacuum system products at a reasonable price, on a timely basis. We are a “one-stop shop” for manufacturers and distributors of vacuum equipment.

**OUR HISTORY:**

National Vacuum Equipment, Inc. was founded in 1980 by Bruce Luoma. The Company started as a retailer of vacuum pumps. Soon after it started, the Company secured the rights to exclusive distribution of the Battioni vacuum pumps in North America. This helped the Company to evolve into its current status as a wholesale supplier.

To reach the goal of becoming a full service supplier of vacuum system components, the Company began fabricating its own line of componentry, purchased and developed its own line of vacuum pumps, and began purchasing for resale various valves and accessories.

Today, NVE has full service machine and fabrication shops complete with CNC-controlled production equipment designed for close tolerance work. The company has a highly trained staff all of whom are dedicated to quality.

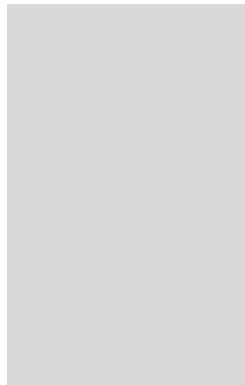

## Limited Warranty

*WPT 480/P*

*WPT 600/P*

*WPT 720/P*

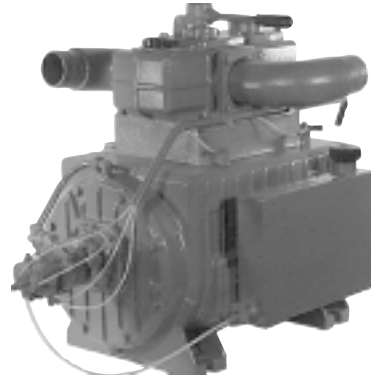

---

### National Vacuum Equipment, Inc.

**guarantees that the product it provides is free of manufacturer's defects, including materials and workmanship. Properly installed and maintained product is warranted for a period of one (1) year subject to the following conditions:**

1. A properly completed warranty registration card must be received by us within 30 days of sale to end user for pump sales to be considered warrantable. All pumps received for warranty consideration must retain the original NVE serial number tag.
2. The one (1) year period shall begin the day the product is shipped from our warehouse, unless we are provided with an authentic copy of the original resale invoice, in which case the one (1) year period shall begin at such invoice date.
3. The covered product must be used in an application for which it was intended. We do not recommend our product for particular uses or applications.

4. Vane breakage, or damage caused by vane breakage, is not warrantable.
5. Damage caused by improper use or lack of proper maintenance is not warrantable.
6. Manufacturer's liability under this or any other warranty, whether express or implied, is limited to repair of or, at the manufacturer's option, replacement of parts which are shown to have been defective when shipped.
7. Manufacturer's liability shall not be enforceable for any product until National Vacuum Equipment, Inc. has been paid in full for such product.
8. Except to the extent expressly stated herein, manufacturer's liability for incidental and consequential damage is hereby excluded to the full extent permitted by law.
9. Manufacturer's liability as stated herein cannot be altered except in writing signed by an officer of National Vacuum Equipment, Inc.
10. Certain products provided by National Vacuum Equipment, Inc. are covered by their respective manufacturer's warranties (e.g., engines used in the NVE engine drive packages). These products are not covered by the National Vacuum Equipment, Inc. Manufacturer's Warranty.

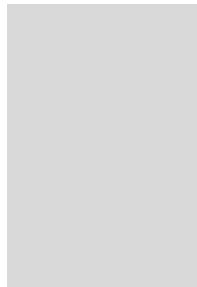

---

**Should a potential warranty situation arise, the following procedures must be followed:**

- Contact your dealer immediately upon the occurrence of the event and within the warranty period.
- Customer must receive a return goods authorization (RGA) before returning product.
- All serial-numbered products must retain the NVE serial number tag to be qualified for warranty.
- Product must be returned to NVE intact for inspection before warranty will be honored.
- Product must be returned to NVE freight prepaid in the most economical way.

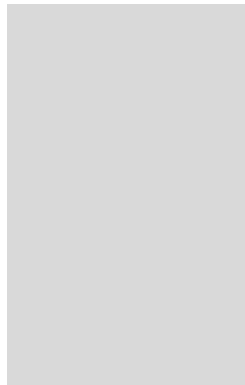

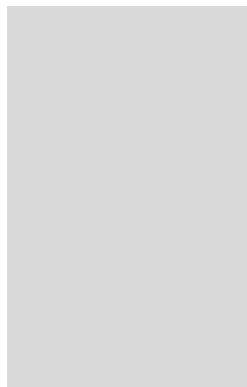

# The WPT Series Pumps

*Model-Specific Information  
for the*

*WPT 480/P*

*WPT 600/P*

*WPT 720/P*

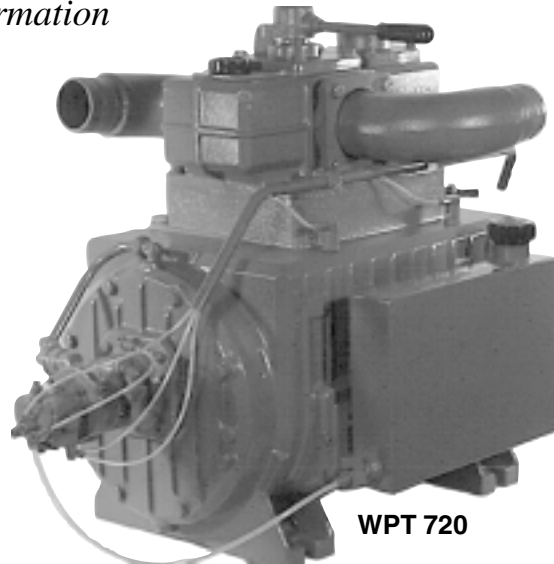

**WPT 720**

---

## WPT Series Pump Specifications

<b><u>Model Number</u></b>	<b><u>480</u></b>	<b><u>600</u></b>	<b><u>720</u></b>
RPM Range	600-1250	600-1250	600-1250
Max. Air Flow-CFM	300	385	467
Max. Continuous Vacuum	25	25	25
Max. Intermittent Vacuum	28	28	28
Max. Continuous Pressure	28	25	25
Max. Intermittent Pressure	30	30	30
Pump Drive Rotation	CW/CCW	CW/CCW	CW/CCW
Porting Size	3 inch	3 inch	3 inch
Manifold With Four Way Valve	Std	Std	Std
End Thrust Protection	Std	Std	Std
Bearings Sealed From Pump Interior	Std	Std	Std
Anti-Spin Check Valve	Std	Std	Std
Automatic Lubrication System	Std-2 pt	Std - 3 pt	Std-4pt
Oil Tank Capacity-Quarts	4	5	6
Net Weight	547 lbs	660 lbs	720 lbs

## Performance

### WPT 480/P PERFORMANCE

		PRESSURE PSI					VACUUM – INCHES OF MERCURY									
RPM		25	20	15	10	5	0	3	6	9	12	15	18	21	24	27
1250	HP	36	30	25	19	13	8	9	10	11	12	14	15	16	18	19
	CFM	216	225	237	254	274	300	293	286	277	271	260	245	228	185	109
1000	HP	28	24	19	14	10	6	7	8	9	10	11	12	13	14	15
	CFM	160	168	182	197	214	237	232	223	214	203	188	174	160	130	80
800	H.P	23	19	15	11	7	4	5	5	6	7	8	9	10	11	12
	CFM	116	127	136	150	165	188	184	174	166	160	156	152	146	120	70

### WPT 600/P PERFORMANCE

		PRESSURE PSI					VACUUM – INCHES OF MERCURY									
RPM		25	20	15	10	5	0	3	6	9	12	15	18	21	24	27
1250	HP	51	42	35	27	19	12	13	15	16	18	19	21	22	24	26
	CFM	312	318	331	346	361	385	380	374	364	355	340	324	303	272	193
1000	HP	39	32	27	20	15	9	10	11	12	13	14	16	17	18	20
	CFM	235	246	256	270	285	323	308	297	288	285	267	250	232	203	144
800	H.P	31	26	20	16	11	6	7	8	9	10	11	12	13	15	16
	CFM	176	191	200	211	226	247	244	235	226	214	198	182	158	117	85

### WPT 720/P PERFORMANCE

		PRESSURE PSI					VACUUM – INCHES OF MERCURY									
RPM		25	20	15	10	5	0	3	6	9	12	15	18	21	24	27
1250	HP	57	49	40	32	23	15	16	18	20	22	24	26	28	30	31
	CFM	388	400	414	427	448	467	464	459	446	434	427	409	390	351	280
1000	HP	47	40	32	24	17	11	12	14	16	18	20	21	22	24	26
	CFM	300	315	330	340	390	380	370	365	360	345	340	320	300	265	210
800	H.P	37	31	26	20	14	8	9	10	12	14	15	16	18	19	20
	CFM	225	240	255	270	290	310	305	300	290	280	270	255	235	205	140

---

## System requirements

### High quality components

- The pump body and rotor are constructed of cast iron with free sliding vanes made of special nonmetallic, heat resistant material.
- Vanes wear evenly because tips always remain in contact with the wall surface.
- For maximum life and proper performance we recommend the use of our compatible components, Portal Shutoff F-800-LC-8-3 and Moisture Trap F-901B.

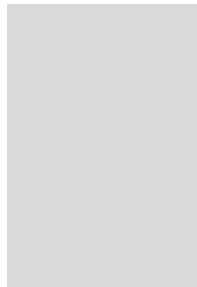

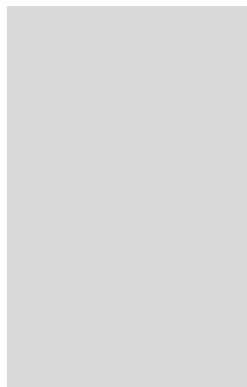

# Operating Instructions

WPT 480/P  
WPT 600/P  
WPT 720/P



---

## Installation

- Check pump rotation. Standard rotation is clockwise unless otherwise marked. See *Determining the Rotation of Pump*.
- Recommended operating speed is 850 to 1000 rpm.
- Pump should always be mounted in a level, horizontal position on a firm, flat surface.
- Grade 5 bolts should be used in installation. It is important to use flat washers and lock washers.
- We recommend the use of oil resistant hose on both the inlet and outlet sides of the pump. If using direct drive system, always use a flexible coupling. We recommend the use of Woods Sure Flex Couplers.
- The drive mechanism should be suitable for the horsepower required to drive the pump.
- Because WPT pumps are fitted with roller bearings the rotor is able to float from side to side. It is important during initial setup that no undue pressure is put on the rotor that would cause the

- Cooling system: normal operating temperature is 140°F - 175°F. Maximum temperature is 200°F.
- Coolant lines should be assembled as follows:
  - a. (Cool water) From coolant source to the circulating pump to the fitting on the top of the rear endplate back to coolant source.
  - b. After filling with coolant, run the circulating pump and recheck the coolant level.
  - c. After running for several minutes, loosen the thermometer slightly to allow any air trapped in the pump to escape. Then retighten the thermometer.
- A 2" pressure relief valve and a 1½" vacuum relief valve have been shipped with your pump and need to be mounted on the top of the pump.

---

## **Automatic oil pump**

- The automatic oil pumps are set at the factory during pump testing and should require no further adjustment during pump installation.
- The pumps are adjusted to one drop every two seconds per outlet. This oil rate equals 2.7 fluid oz. per hour.

---

## **Adjusting the automatic oil pump**

The automatic oil pump is a metered piston-type pump.

If you wish to adjust the pump, please follow these instructions:

### **Adjusting the oil rate**

Oil flow is changed by adjusting the length of the stroke of the piston.

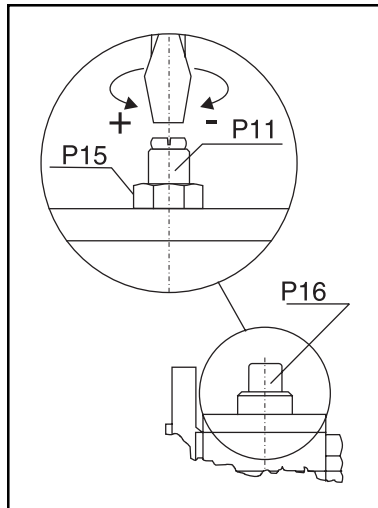

1. To adjust the oil rate, remove cap #P16. Under this cap you will find a jam nut #P15 and adjusting screw #P11.
2. To adjust oil rate loosen jam nut and turn adjusting screw clockwise to reduce oil flow or counterclockwise to increase oil flow.
3. When making adjustments do so one turn of the screw at a time and test before making further adjustments.
4. Be careful to not turn adjusting screw too far counterclockwise as you may disengage the gears and strip them

out.

### Testing flow rate after adjustment

1. Observe oil drip rate in oil view meter or oil line to ensure adequate lubrication.
2. Adjustments should be done gradually so as not to starve the vacuum pump of oil.

---

### Recommended lubrication

We recommend that turbine grade oil be used in all our pumps. Turbine oil is more highly refined than motor oil and is much less likely to create carbon. Turbine oil is available from your local oil distributor. Below is a list of acceptable oils.

- Penzoil Penzabell 68 T.O.
- Shell Turbo 68
- Mobil D.T.E. Heavy – Medium

- Texaco Regal R.N.O. 68

---

**Normal operation for liquid cooled pumps:**

1. Check oil reservoir daily and fill as required.
2. When the pump is in operation, check the oiler to insure flow of oil to the pump.
3. Do not operate the pump faster than recommended rpm.
4. If an in-line 12 volt circulating pump is used, make sure it is turned on.
5. Always monitor the water temperature gauge.
6. To operate the suction valve on top of the pump, move the handle in the appropriate direction for either vacuum or pressure. Center it for neutral.
7. We recommend periodic cleaning of your pump. To do this, remove the suction line from the pump. Move the suction valve to neutral, run the pump at an idle, and pour into the pump intake one pint of diesel fuel. Allow the pump to run a short time, move the suction valve to vacuum, and blow out the diesel fuel and dirt. Move the suction valve to neutral and pour in a pint of oil. Allow the pump to run a short time before reassembling.
8. We recommend checking vane wear every twelve months. A new vane is nearly flush with the rotor. Measure the wear and if is over 1/4" we recommend

replacing vanes. It's good to always keep a spare set of vanes on hand for emergencies.

---

## **Maintenance**

- Oil should be supplied to pump at a rate of 1 drop every 2 seconds.
- Average usage of oil is approximately 1-2 qts. per 40 hours, depending on operation.
- Normal vane life is approximately 2000 hours; however, this will vary greatly with temperature, material being pumped, and proper maintenance. Occasionally, liquid and dirt may enter the pump, causing vanes to stick in the rotor slots, along with excessive vane and housing wear. When this occurs, you must clean the inside of the pump.

---

## **Determining the rotation of the pump**

### **As one faces the drive end of the pump:**

- If the oiler is on the right, the pump shaft turns clockwise.

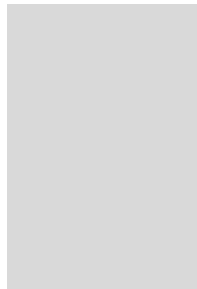

- If the oiler is on the left, the pump shaft turns counterclockwise.

## WPT Pump Cooling System

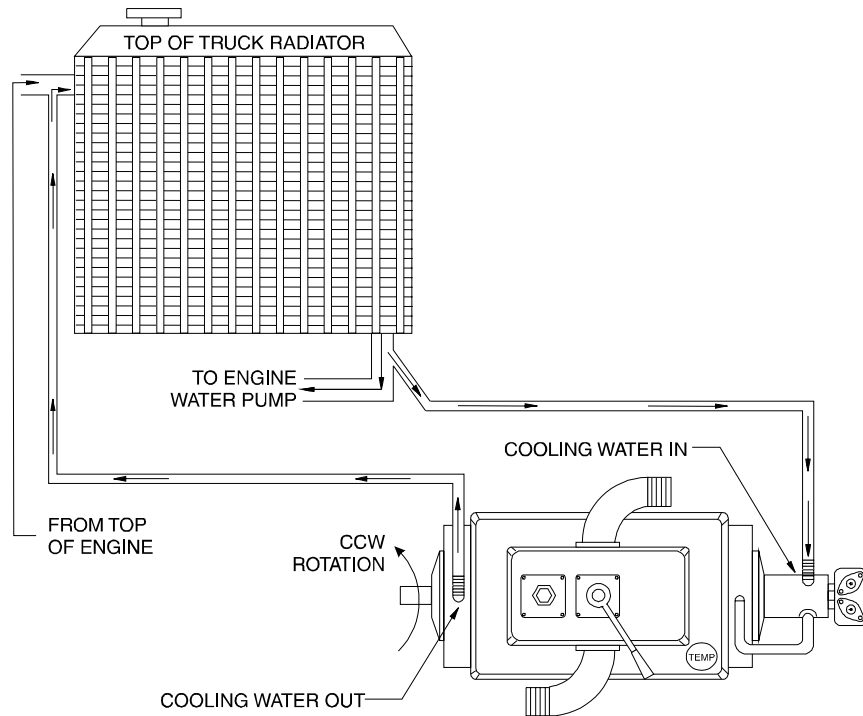

- Because vacuum pumps generate large amounts of heat during operation, consideration of pump cooling is very important.
- If you are installing a liquid cooled pump, follow the pump manufacturers recommendations for pump cooling.
- Make sure all guards are in place.
- With liquid cooled pumps it is a good idea to install shutoff valves in the water lines.

- Before operating the pump, bleed any air from the system by loosening the thermometer.

## Troubleshooting

*WPT 480/P*

*WPT 600/P*

*WPT 720/P*



---

### Pump overheats

- Inlet water temperature too high
- Inadequate water flow
- No oil in pump
- Oil adjustment set too lean
- RPM too fast
- Prolonged operation

---

### Too much oil use

- Oil adjustment set too rich
- Oil seals defective

- Cracked pump body

---

### **Pump doesn't turn**

- Broken vane
- Frozen
- Pump endplate bolts too tight
- Faulty PTO or drive set up

---

### **No vacuum or pressure in tank**

- Suction valve in neutral
- Defective seal or vanes
- Pump not driven fast enough
- Check valve or suction line clogged

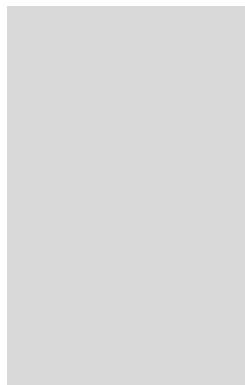

- Leak in tank or fittings

## Pump Rebuilding

*WPT 480/P*

*WPT 600/P*

*WPT 720/P*



**Please read these instructions completely before attempting repair.**



---

### Complete rebuild

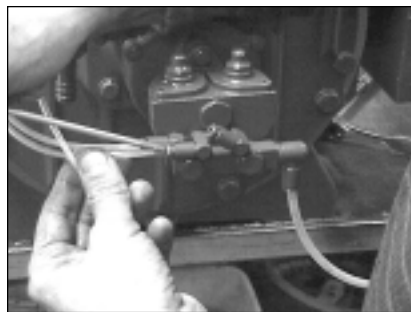

1. Remove the drain plug on the bottom of the rear endplate.
2. Remove the oil lines from the oil pump.

The oil lines are self-locking.

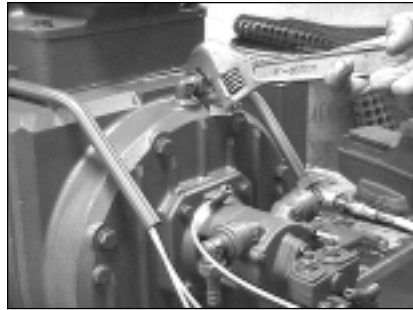

Push the lock ring toward the fitting while pulling the oil line out of the fitting.

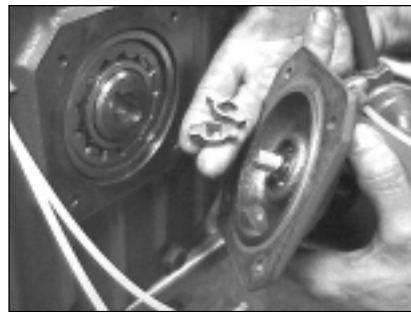

3. Remove the coolant line from the rear endplate.
4. Remove the bolts holding the water pump to the endplate and remove the water pump assembly.

Make sure not to lose the pump drive tab.

For pumps without the built-in water pump, simply remove the bearing cover with the oil pump attached.

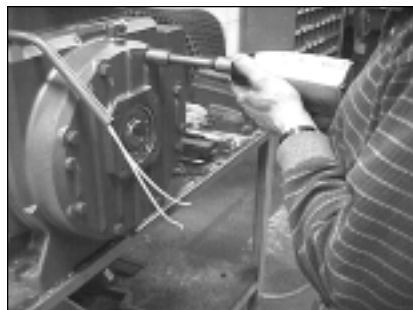

5. Loosen the bolt holding the endplate to the housing and remove the endplate.

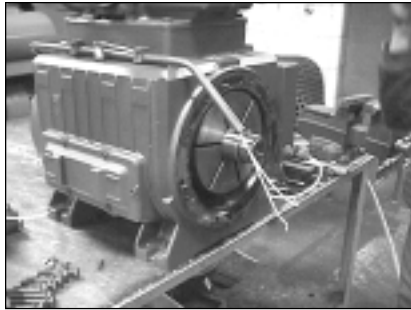

The WPT pumps are equipped with roller bearings, so no special pullers are required.

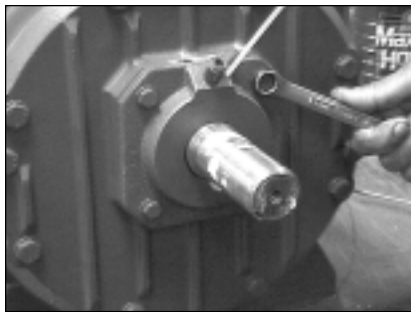

Note the number of gaskets.

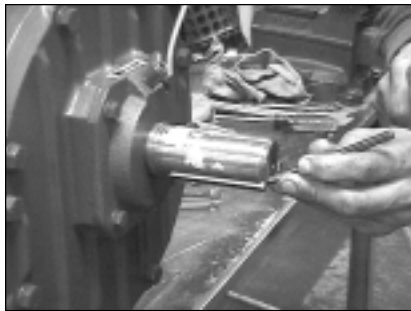

Place a pan under the endplate to catch escaping

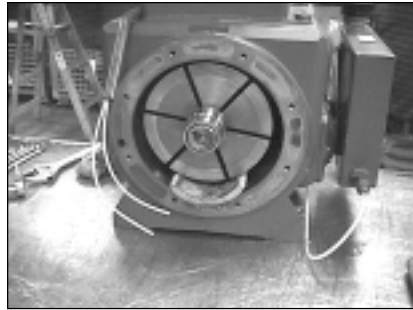

coolant.

6. Remove front oil line and shaft key.
7. Remove front bearing cover and coolant line.
8. Use a block or wood or heavy cardboard to cushion the rotor.
9. Place a mark on the front endplate and on the front of the housing for identification purposes.

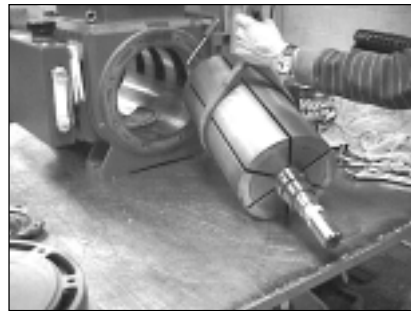

Support the front end of the rotor and remove the endplate bolts.

Lower the rotor to the bottom of the housing.

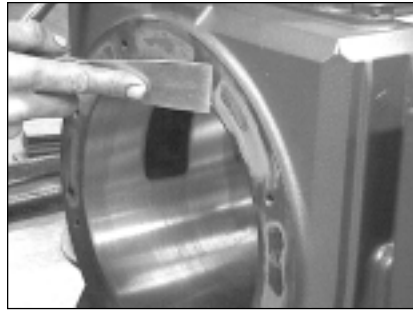

10. Slide the endplate off the rotor and remove the rotor from the housing.

Note the number of gaskets.

11. Inspect the housing bore and renew as necessary.

The pump bore new is 9.840 inches.  
The maximum overbore recommended is .060 inch.

Thoroughly clean the housing and scrape off the old endplate gaskets.

The side cover gaskets are usually not removed during a normal rebuild.

12. Thoroughly clean the rotor, paying particular attention to the slots.

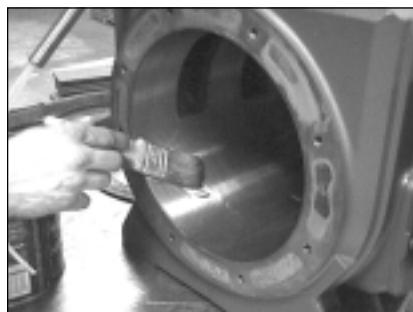

Inspect the rotor for nicks or burrs and remove as necessary.

When you are finished the vanes should slide freely in the slots.

13. Lubricate the housing bore.



Place the cushion used earlier back into the bore and install the rotor, making sure the long end of the rotor is in the proper end of the housing.

14. Remove the bearings and seals.

If your intention is to reuse the bearings, carefully drive the bearings out using a small hammer and punch.

Work the bearing out slowly. They can be easily damaged.



Thoroughly clean the endplate and scrape off any remaining gasket material.

Make sure the oil passage through the endplate is clear.



15. Install new seals and the bearings.

The seals mount back to back and should be driven to the bottom of the endplate.

Each bearing should be driven until it makes contact with the bottom of the endplate.



The bearings are of different thicknesses, which is apparent upon inspection. Make sure you are installing them in the proper endplate.

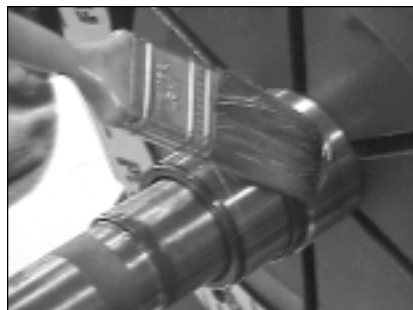

The heavier bearing goes into the drive endplate.

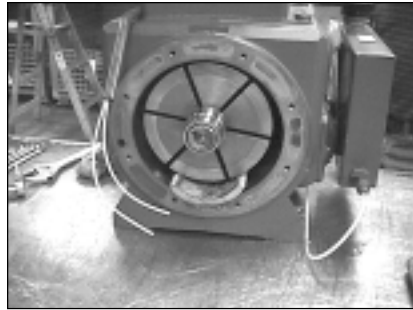

16. Apply a hardening gasket sealer to the front plate and to the end of the pump housing.

17. Lubricate the front seal sleeve, seals and bearing.

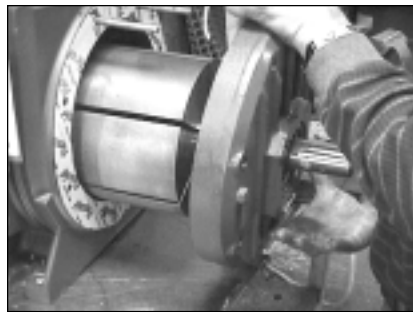

18. Slide the rotor into the housing, making sure the input shaft is protruding from the drive end of the housing.

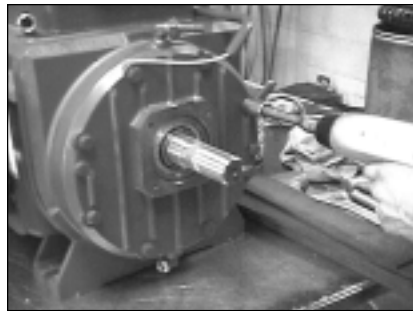

Install the cushion used earlier in the non-drive end.



19. Install the same number of endplate gaskets on the housing and slide the drive endplate onto the drive end of the rotor.



20. Raise the rotor and the endplate assembly up and install the endplate bolts.

21. Remove the cushion previously used from the housing and install the vanes.

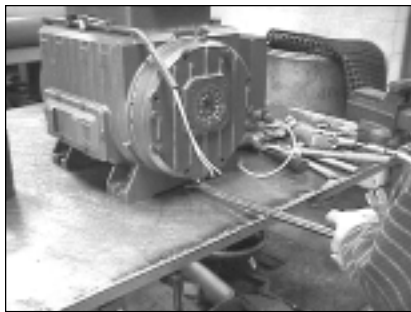

Make sure the round end is facing out of the rotor.

22. Apply sealer to the rear endplate and housing and install the proper number of gaskets on the rear of the housing.

*Important:* Make sure the water passage hole on the gasket is lined up

with the water passage hole in the housing.

23. Slide the rear endplate on to the rotor.

Raise the assembly up and install the endplate bolts.



When the endplate is nearly touching the housing, pry the assembly up to



set the seal gap.

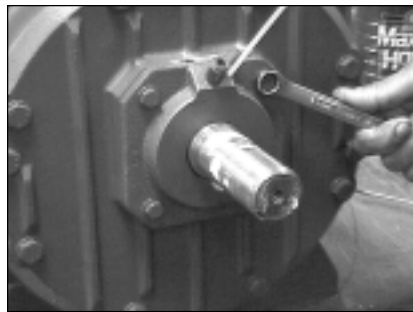

Loosen the front endplate bolts and pry the front endplate while tightening the bolts.

This is particularly important if you have honed or bored your housing.

24. Seat the bearings, front and rear.

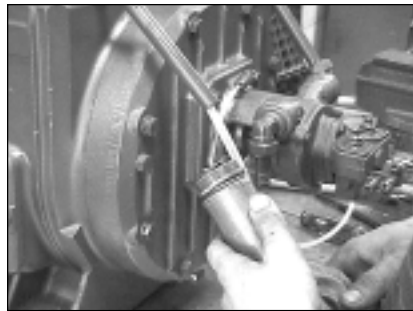

25. You should now be able to turn the pump by hand.

26. Clean the front bearing cover and replace the seal.

Lubricate the seal and rotor.

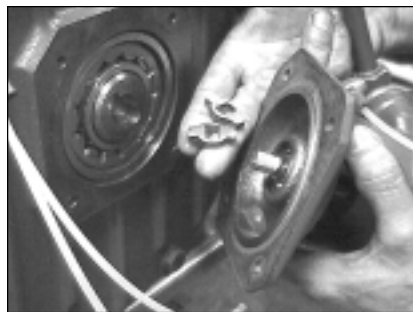

Use sealer on the gasket and install the bearing cover on the front endplate.

27. Using an oil squirt can, pump six squirts into the bearing cavity through the oil fitting.

Reinstall the oil line.

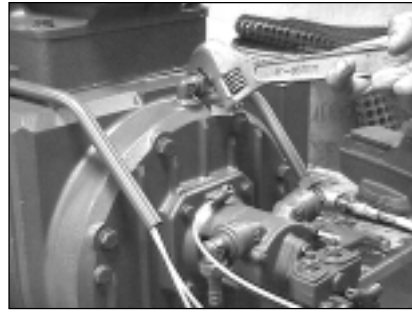
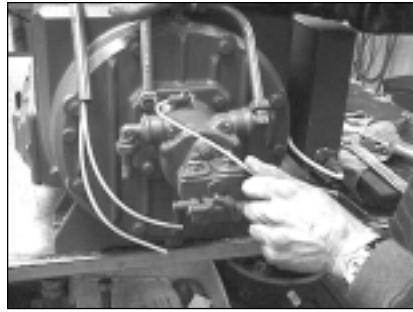

28. Install the drive tabs in the rear of the rotor and install the water pump assembly, using sealer on the gasket.

Make sure the water pump drive lines up with the tabs.

During this operation, you must also position the water line in the fitting at the top of the endplate.

29. Reinstall the oil lines at the oil pump.



Make sure the lines going to the bearings are attached to the same side of the oil pump to ensure equal oiling to each bearing.

If the oil lines leak, trim the ends with a razor knife to get a clean end.

Insert the line into the fitting and pull back to seat the line on to the fitting.

Tighten the coolant fitting to the endplate and the water pump.

30. Reinstall the front coolant line.
31. The pump is now ready to run.

Start the pump and turn as slowly as possible.

# Parts Diagram

National Vacuum Equipment, Inc.

WPT 480/P  
WPT 600/P  
WPT 720/P

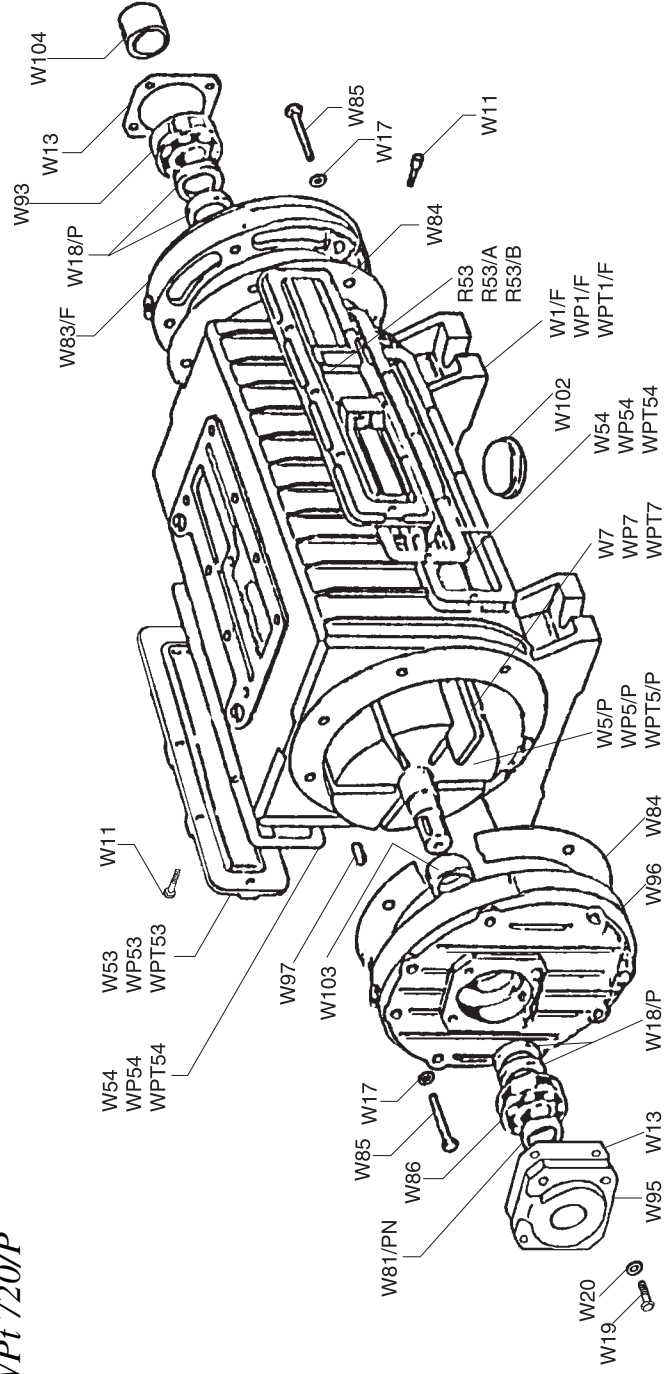

Part #	Description	Part #	Description
R53	Cover - 480 (oil)	W20	Washer (18)
R53/A	Cover - 600 (oil)	W53	Cover - 480
R53/B	Cover - 720 (oil)	WP53	Cover - 600
W1/F	Housing - 480	WPT53	Cover - 720
WP1/F	Housing - 600	W54	Gasket - 480
WPT1/F	Housing - 720	WP54	Gasket - 600
W5/P	Rotor -480/P	WPT54	Gasket - 720
WP5/P	Rotor - 600/P	W81/PN	Seal (45-62-10)
WPT5/P	Rotor - 720/P	W83/F	Rear Endplate
W7-4	Vane 480	W84	Gasket
W7-6	Vane - 480	W85	Bolt (m1x70)
WP7	Vane - 600	W86	Bearing (NJ2309)
WPT7-4	Vane 720	W93	Bearing (NJ309)
WPT7-6	Vane 720	W95	Bearing Cover
W11	Bolt (m8x16)	W96	Front Endplate
W13	Gasket	W97	Key (10x8x80)
W17	Washer (10)	W102	Frost Plug
W18/P	Seal (65x85x10)	W103	Seal Sleeve
W19	Bolt (m8x20)	W104	Seal Sleeve

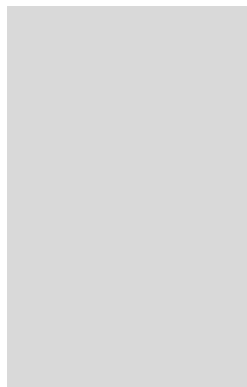

# Four-Way Valve Assembly

WPT 480 – WPT 600 – WPT 720

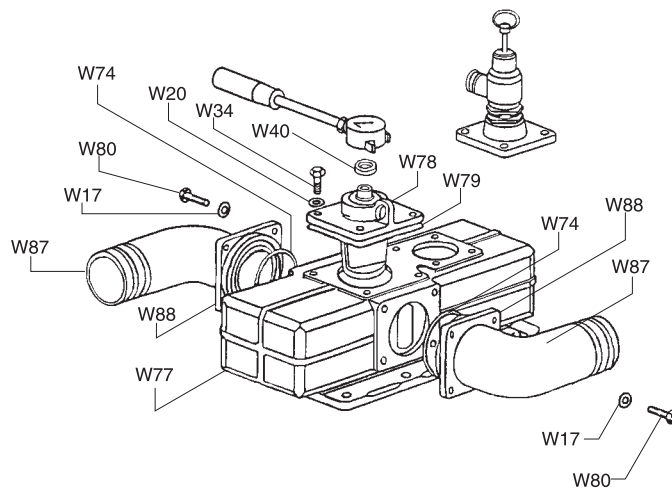

## Part # Description

---

- W17 Washer
- W20 Washer
- W34 Bolt (m.8x25)
- W40 Seal (35-50-7)
- W74 O-Ring
- W77 4-Way Valve Housing
- W78 4-Way Valve Cover
- W79 Gasket
- W80 Bolt (m.10x45)
- W87 Air Horn
- W88 Flange Clamping





## Lubrication/Cooling System

WPT 480 – WPT 600 – WPT 720

Part #	Description
LW32D	Oil Pump – 480 CW
LW32S	Oil Pump – 480 CCW
LW32AD	Oil Pump – 600 CW
LW32AS	Oil Pump – 600 CCW
LW32BD	Oil Pump – 720 CW
LW32BS	Oil Pump – 720 CCW
R1	Oil Protector Tube – 480
R1/A	Oil Line Protector Tube – 600
R1/B	Oil Line Protector Tube – 720
R2	Dripper
R3	Fitting
R7	Brass Coolant Line
R8	Bolt (m6x12)
R9	Bracket
R10	Hose
R10/A	Hose
R10/B	Hose

## Part # Description

R12	Hose
R13	Hose
R13/A	Hose
R15	90° Fitting
R16	Hose
R19	Washer
R20	Oil Fill Cap
R23	Brass Coolant Line
R26	Key (m5x6)
R28	Ring
R30	Bolt
R31	Gasket
R32D	Oil Pump – 480 CW
R32S	Oil Pump – 480 CCW
R32AD	Oil Pump – 600 CW
R32AS	Oil Pump – 600 CCW
R32BD	Oil Pump – 720 CW
R32BS	Oil Pump – 720 CCW
R33	Washers
R34	Bolt (m6x16)
R35	Fitting
R36	Fitting
R37	Fitting
R37-1	Fitting - Straight

Part #	Description	Part #	Description
R38	Bearing (60002RS)	R69	Washer (8)
R39	Seal (12x20x5)	R70	Bolt (m8x20)
R40	Impeller	R71	Coolant Tube
R43	Bearing (6201)	R72	Elbow
R45	Hose	R73	Filter
R45/A	Hose	R74	Washer (1/2" gas)
R45/B	Hose	R75	Adapter
R46	Bushing	R76	Washer (1/8" gas)
R47	Valve	R77	Distribution Block
R52D	Oil Tank- 480 CW	R79	Bolt (1/8"x30)
R52S	Oil Tank - 480 CCW	R89	Shaft
R52AD	.....Oil Tank - 600/720 CW	R90	Packing
R52AS	Oil Tank - 600/720 CCW	R91	Snap Ring
R53	Cover - 480 (Oil)	R92	Washer
R53/A	Cover - 600 (Oil)	R93	Water Pump Housing
R53/B	Cover - 720 (Oil)	R94	Rear Bearing Cover
R54	Sight Tube	R100	Oil Line - Small - Bulk
R59	Snap Ring	R101	Oil Line - Large - Bulk
R60	Seal (15x26x7)		
R64	O-Ring		
R65	Impeller Cover		
R66	Spacer (20x28x2)		
R67	Drive Tab		
R68	Tube		

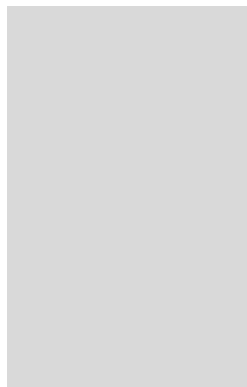



# Automatic Oil Pump

WPT 480 – WPT 600 – WPT 720

See Parts List on page 45

## Three and Four Outlet Type

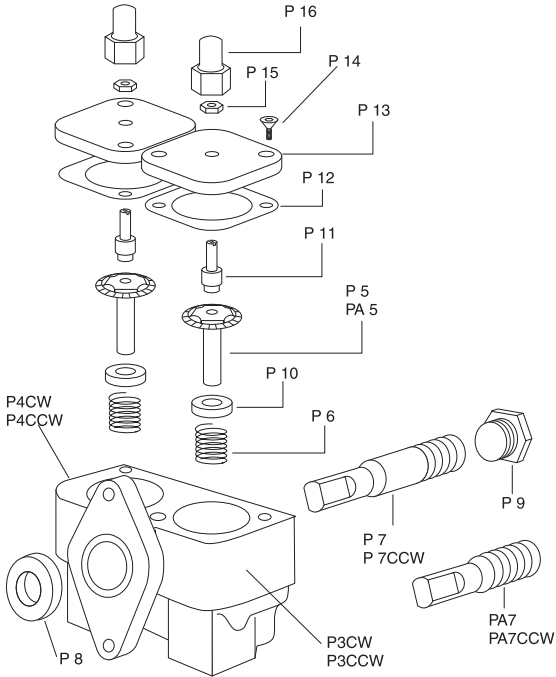

# Automatic Oil Pump

*WPT 480 – WPT 600 – WPT 720*

## Oil Pump – Long Shaft (w/o Water Pump)

<u>Part #</u>	<u>Description</u>
LW32D	Oil Pump – 480 (CW)
LW32S	Oil Pump – 480 (CCW)
LW32AD	Oil Pump – 600 (CW)
LW32AS	Oil Pump – 600 (CCW)
LW32BD	Oil Pump – 720 (CW)
LW32BS	Oil Pump – 720 (CCW)

## Oil Pump – Short Shaft (w Water Pump)

<u>Part #</u>	<u>Description</u>
R32D	Oil Pump – 480 (CW)
R32S	Oil Pump – 480 (CCW)
R32AD	Oil Pump – 600 (CW)
R32AS	Oil Pump – 600 (CCW)
R32BD	Oil Pump – 720 (CW)
R32BS	Oil Pump – 720 (CCW)
P1CW	Pump Body – 1 Outlet – CW
P1CCW	Pump Body – 1 Outlet – CCW
P2CW	Pump Body – 2 Outlet – CW
P2CCW	Pump Body – 2 Outlet – CCW
P3CW	Pump Body – 3 Outlet – CW
P3CCW	Pump Body – 3 Outlet – CCW
P4CW	Pump Body – 4 Outlet – CW
P4CCW	Pump Body – 4 Outlet – CCW
P5	Driven Gear – CW
PA 5	Driven Gear – CCW
P6	Spring
P7	Driving Gear – Long Shaft – CW
P7CCW	Driving Gear – Long Shaft – CCW
PA7	Driving Gear – Short Shaft – CW
PA7CCW	Driving Gear – Short Shaft – CCW
P8	Seal
P9	Plug
P10	Retainer
P11	Adjusting Screw
P12	Gasket
P13	Lid
P14	Screw
P15	Jam Nut
P16	Cap

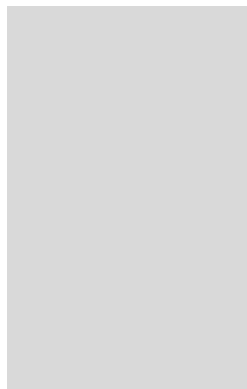

# Index

## A

Air Flow 11

## B

Bearing

11, 19, 25, 29, 30, 34

Bearing cover 29, 31, 34

Bearing driver 34

Bore 30

## C

Check Valve, Anti-Spin 11

Check valve ball 30

Cleaning 19

Clockwise 20

Components 13

Counterclockwise 20

Coupling 15

Cushion 29

Cushion material 32

## D

Diesel fuel 19

Dripper 16, 19

Drive key 24, 28, 35

## E

Endplate 21, 24, 29, 32, 33

## F

Factory Settings 17

Four way valve 30

## G

Gasket sealer 26, 31, 33

Gaskets 20, 25, 30, 31, 33

Greasing 19

Guides 31

## H

Hose 15

Housing 25, 29

Housing bore 31

Housing, boring or honing 30

Hydraulic press 29

## I

Identifying mark 29

Installation 15

Instructions, rebuilding 23

## J

Jam nut 17

## L

Lubricate 26, 31

Lubrication 11, 16

Lubrication rate 19

## M

Maintenance 8

Manifold 11

Manufacturer's warranties 9

Moisture Trap F-901 13

Muffler 15

## O

Oil 19

Oil adjustment 21

Oil lines 7, 28

Oil pump 7, 16

Oil pump shaft 28

Oil rate 16

Oil reservoir 18

Oil tank capacity 11

Oil, turbine grade 18

Oil, using too much 21

Oiler 18, 20

Operation, normal 18

Outboard bearing 34

Overheating 21

Owner's Record 1

## P

Parts List 37, 40, 42, 46

Performance 12

Piston 17

Portal F-801 13

Porting size 11

Pressure, continuous 11

Pressure, intermittent 11

Pressure relief valve 19

Prybar 34

PTO 21

Pull holes 24

Puller 29

Pump body 13

Pump doesn't turn 21

Pump, piston-type 17

Punch 34

## R

Rebuild, complete 29

Rebuilding 23

Recommended Lubrication  
18

Registration card 7

Repair 23

Return goods authorization 9

Rotation 11, 15

Rotation, changing 20

Rotor 13, 25, 29, 30, 32

Rotor shaft 29

Rotor slots 25

Rotor-endplate assembly 32

RPM 18, 21

RPM Range 11

## S

Seal sleeve 27, 31

Seals 20, 21, 25, 26, 30

Serial number 7

Serial number tag 9

Specifications 11

System requirements 13

## **T**

Tank 22  
Threaded rod 31  
Torque 27, 34  
Troubleshooting 21  
Turbine oil 18

## **V**

Vacuum, continuous 11  
Vacuum, intermittent 11  
Vacuum, none in tank 22  
Valve, changeover 19  
Valve, check 22  
Valve, four way 11  
Valve, pressure relief 19  
Valve, suction 18  
Vane 13, 19, 21  
Vane breakage 8  
Vane life 19  
Vane replacement 23, 29  
Vane wear 18  
Vanes 25, 30, 33  
Vanes, chipped or delaminated  
25, 30

## **W**

Warranty 7  
Warranty procedure 9  
Washers 15  
Weight 11  
Woods Sure Flex Couplers 15

