

MECII 9000/P MECII 11000/P

Owner's Record

Date of Purchase: _____

Purchased from: _____

Serial Number: _____



NVE

National Vacuum Equipment, Inc.

© 2010 National Vacuum Equipment, Inc.
September 2010

No part of this manual may be reproduced without the written permission of
National Vacuum Equipment, Inc.

CONTENTS

Introduction

About National Vacuum Equipment, Inc.....	5
---	---

Limited Warranty

Warranty.....	6
Warranty Procedures.....	8

The MEC Series Pumps

Pump Specifications.....	10
Performance.....	11
System Requirements.....	12

Operating Instructions

Installation.....	13
Lubrication procedure.....	14
Automatic oil pump.....	14
Adjusting the automatic oil pump.....	15
Recommended lubrication.....	16
Normal operation for air cooled pumps.....	16
Maintenance.....	17
Determining the rotation of the pump.....	18

Troubleshooting

Pump overheats.....	19
Too much oil use.....	19
Pump doesn't turn.....	19
No vacuum or pressure in tank.....	19

Parts List - MECII /P Series Pumps

Parts Diagram20
Parts List21
Ballast Check Valve Parts List22
Ballast Check Valve Diagram22

Parts Details - Lubrication Systems

Automatic Lubrication System24
Automatic Oil Pump26
Gear-Type Lubrication System28

INTRODUCTION

General Information



About National Vacuum Equipment

Congratulations! You now own a quality vacuum/pressure pump proudly manufactured in Italy by Battioni Pagani Pome S.p.A. You have not only acquired a superior piece of equipment from a qualified dealer, you have hired a team of vacuum experts. We stand ready to work with your dealer to answer your questions and provide you with the information necessary to keep your equipment in peak working condition.

Thank you for using National Vacuum Equipment.

Our Mission

NVE is dedicated to the manufacture and wholesale distribution of quality vacuum system products at a reasonable price and delivered on a timely basis. NVE is a “one-stop shop” for manufacturers and distributors of vacuum equipment.

Our History

National Vacuum Equipment, Inc. was founded in 1980 by Bruce Luoma. NVE started as a retailer of vacuum pumps. Soon after it started, NVE secured the rights to exclusive distribution of the Battioni vacuum pumps in North America. This allowed NVE to evolve into its current status as a wholesale supplier.

To reach the goal of becoming a full service supplier of vacuum system components, NVE began fabrication its own line of componentry, purchased and developed its own line of vacuum pumps, and began purchasing for resale various valves and accessories.

Today, NVE has full service machine, fabrication and powder-coating shops complete with CNC-controlled production equipment designed for close tolerance work. Our staff is highly trained and are committed to quality from start to finish.

LIMITED WARRANTY

Warranty

National Vacuum Equipment, Inc. guarantees that the product it provides is free of manufacturer's defects, including materials and workmanship. Properly installed and maintained product is warranted for a period of one (1) year subject to the following conditions:

1. A properly completed warranty registration card must be received by us within 30 days of sale to end user for pump sales to be considered warrantable. All pumps received for warranty consideration must retain the original NVE serial number tag.
2. The one (1) year period shall begin the day the product is shipped from our warehouse, unless we are provided with an authentic copy of the original resale invoice, in which case the one (1) year period shall begin at such invoice date.
3. The covered product must be used in an application for which it was intended. We do not recommend our product for particular uses or applications.
4. Vane breakage, or damage caused by vane breakage, is not warrantable.
5. Damage caused by improper use or lack of proper maintenance is not warrantable.
6. Manufacturer's liability under this or any other warranty, whether express or implied, is limited to repair of or, at the manufacturer's option, replacement of parts which are shown to have been defective when shipped.

7. Manufacturer's liability shall not be enforceable for any product until National Vacuum Equipment, Inc. has been paid in full for such product.
8. Except to the extent expressly stated herein, manufacturer's liability for incidental and consequential damage is hereby excluded to the full extent permitted by law.
9. Manufacturer's liability as stated herein cannot be altered except in writing signed by an officer of National Vacuum Equipment, Inc.
10. Certain products provided by National Vacuum Equipment, Inc. are covered by their respective manufacturer's warranties (e.g., engines used in the NVE engine drive packages). These products are not covered by the National Vacuum Equipment, Inc. Manufacturer's Warranty.
11. Final assemblers responsibility. NVE goes to great lengths to insure the quality and proper functionality of the products it supplies. Many products we supply are purchased for resale or are impossible or impractical to test prior to the installation of the item in a vacuum system. It is therefore the responsibility of the final assembler to thoroughly test the vacuum system and components supplied to the assembler by NVE prior to the delivery of the final product to the end user.

Any items found to be defective after delivery to the end user that should have been discovered prior to delivery will qualify replacement of the defective part only with absolutely no compensation for outside labor or travel expenses. Any subsequent damage to other components caused by the defective part will be the sole responsibility of the assembler.

WARRANTY PROCEDURES

Should a potential warranty situation arise, the following procedures must be followed:

- Contact your dealer immediately upon the occurrence of the event and within the warranty period.
- Customer must receive a return goods authorization (RGA) before returning product.
- All serial-numbered products must retain the NVE serial number tag to be qualified for warranty.
- Product must be returned to NVE intact for inspection before warranty will be honored.
- Product must be returned to NVE freight prepaid in the most economical way.
- Credit will be issued for material found to be defective upon our inspection, based upon prices at the time of purchase.

The MECII Series Pumps

*Model-Specific Information
for the
MECII 9000/P
MECII 11000/P*



MEC Series Pump Specifications

<u>Model Number</u>	<u>9000</u>	<u>1100</u>
RPM Range	800-1500	800-1500
Max. Air Flow-CFM	320	394
Max. Intermittent Vacuum	27	27
Max. Intermittent Pressure	30	30
Pump Drive Rotation	CW/CCW	CW/CCW
Porting Size	3 inch	3 inch
Manifold With Four Way Valve	Std	Std
Oil Tank Capacity-Quarts	2 1/2	3 1/4
Bearings Sealed From Pump Interior	Std	Std
Anti-Spin Check Valve	Std	Std
Automatic Lubrication System	Std	Std
Net Weight	288	321

System requirements

High quality components

- The pump body and rotor are constructed of cast iron with free sliding vanes made of special nonmetallic, heat resistant material.
- Because vanes are nonmetallic, flammable fluids may be handled without danger.
- Vanes wear evenly because tips always remain in contact with the wall surface.
- For maximum life and proper performance we recommend the use of our compatible components.

Operating Instructions

MECII 9000/P
MECII 11000/P



Installation

- Check pump rotation. See **Determining the Rotation of Pump**.
- Pump should always be mounted in a level, horizontal position on a firm, flat surface.
- Grade 5 bolts should be used in installation. It is important to use flat washers and lock washers.
- We recommend the use of oil resistant hose on both the inlet and outlet sides of the pump. If using direct drive system, always use a flexible coupling. We recommend the use of Woods Sure Flex Couplers.
- If a muffler is used on discharge side of pump, inlet and outlet of muffler must be at least equal to inside diameter of pump outlet.

Lubrication procedure for all vacuum pumps on start up
(This procedure must be followed prior to the operation of a new vacuum pump.):

Automatic oil pump

- The automatic oil pumps are set at the factory during pump testing and should require no further adjustment during pump installation.
- The pumps are adjusted to one drop every two seconds per outlet. This oil rate equals 2.7 fluid oz. per hour. • With force feed lubrication type, install dripper on top of pump and connect rubber lines.*
- Remove dipstick and fill oil reservoir with recommended turbine oil.
- Remove plastic cap on air inlet and pour 2 oz. turbine oil into pump. Start pump slowly and with valve in suction position, pour 2 oz. turbine oil into air inlet.

Adjusting the automatic oil pump

The automatic oil pump is a metered piston-type pump.

If you wish to adjust the pump, please follow these instructions:

Adjusting the oil rate

Oil flow is changed by adjusting the length of the stroke of the piston.

1. To adjust the oil rate, remove cap #P16. Under this cap you will find a jam nut #P15 and adjusting screw #P11.
2. To adjust oil rate loosen jam nut and turn adjusting screw clockwise to reduce oil flow or counterclockwise to increase oil flow.
3. When making adjustments do so one turn of the screw at a time and test before making further adjustments.
4. Be careful to not turn adjusting screw too far counterclockwise as you may disengage the gears and strip them out.

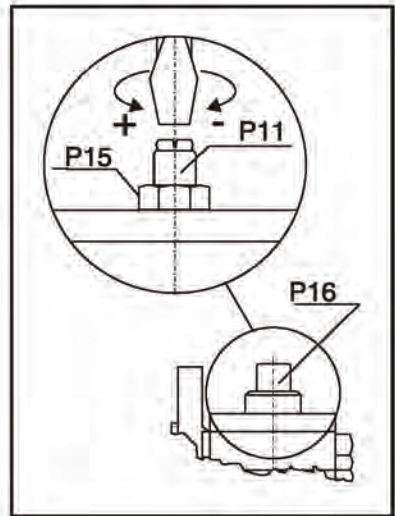

Testing flow rate after adjustment

1. Observe oil drip rate in oil view meter or oil line to ensure adequate lubrication.
2. Adjustments should be done gradually so as not to starve the vacuum pump of oil.

Recommended lubrication

We recommend that turbine grade oil be used in all our pumps. Turbine oil is more highly refined than motor oil and is much less likely to create carbon. Turbine oil is available from your local oil distributor. Below is a list of acceptable oils.

Acceptable oils include:

1. *NVE ISO 68 Oil
2. Penzoiil Penzabell 68 T.O.
3. Shell Turbo 68
4. Mobil D.T.E. Heavy - Medium
5. Texaco Regal R & O 68

* NVE ISO 68 Oil is our recommended pump oil for the Challenger series vacuum pumps. Challenger Vacuum Pump Oil is sold by the case, six 1 gallon containers of oil per case.

Normal operation for air cooled pumps:

1. Check oil reservoir daily and fill as required.
2. When pump is in operation check oiler to insure flow of oil to pump.
3. Do not operate pump faster than recommended RPM.
4. To operate suction valve on top of pump, move handle in the appropriate direction for either vacuum or pressure; center it for neutral.
5. We recommend checking vane wear every twelve months. A new vane is nearly flush with the rotor. Measure the wear and if is over 1/4" we recommend replacing vanes. It's good to always keep a spare set of vanes on hand for emergencies.

Maintenance

- Average usage of oil is approximately 1-2 qts. per 40 hours, depending on operation.
- Oil should be changed every 2000 hours in gear per housing, if equipped.
- Front bearing should be greased approximately every 4 months. Use caution when greasing bearing not to over grease, as this can cause damage to seals.
- Normal vane life is approximately 2000 hours; however, this will vary greatly with temperature, material being pumped and proper maintenance.
- Occasionally liquid and dirt may enter the pump causing vanes to stick in the rotor slots along with excessive vane and housing wear. When this occurs you must clean the inside of the pump.

Cleaning the inside of the pump

- Remove air inlet hose or pressure relief valve.
- Run pump at an idle with the changeover valve in neutral.
- Pour 1 pint of diesel fuel into pump through the air inlet or fitting. Allow pump to run for 30 seconds then turn the change over valve to vacuum.
- Repeat two steps above several times, and then pour 2 oz. of oil into the pump and reassemble.
- *Stop pump and turn slowly by hand while listening for vanes dropping. All vanes should move freely in the rotor slot.*

- It is good practice to clean your pump on a regular basis as this will normally increase the life of your pump greatly.
- Vane wear should be checked every 12 months. A new vane will be flush with the outside diameter of the rotor.
- When vane wear exceeds 1/4" the vanes should be replaced. It is a good idea to have an extra set of vanes, seals and gaskets on hand at all times.

Determining the rotation of the pump

As one faces the drive end of the pump:

- For 1000 RPM pumps with the oiler on the right side, the pump shaft turns clockwise.
- If you must change the rotation of your pump contact the factory for instructions before attempting it.

Troubleshooting

MECII 9000/P
MECII 11000/P



Pump overheats

- No oil in pump
- Oil adjustment set too lean
- Rpm too fast
- Prolonged operation

Too much oil use

- Oil adjustment set too rich
- Oil seals defective
- Cracked pump body

Pump doesn't turn

- Broken vane
- Frozen
- Pump endplate bolts too tight
- Faulty PTO or drive set up

No vacuum or pressure in tank

- Suction valve in neutral
- Defective seal or vanes
- Pump not driven fast enough
- Check valve or suction line clogged
- Leak in tank or fittings

MECII 9000/P - MECII 11000/P

MECII Parts Diagram

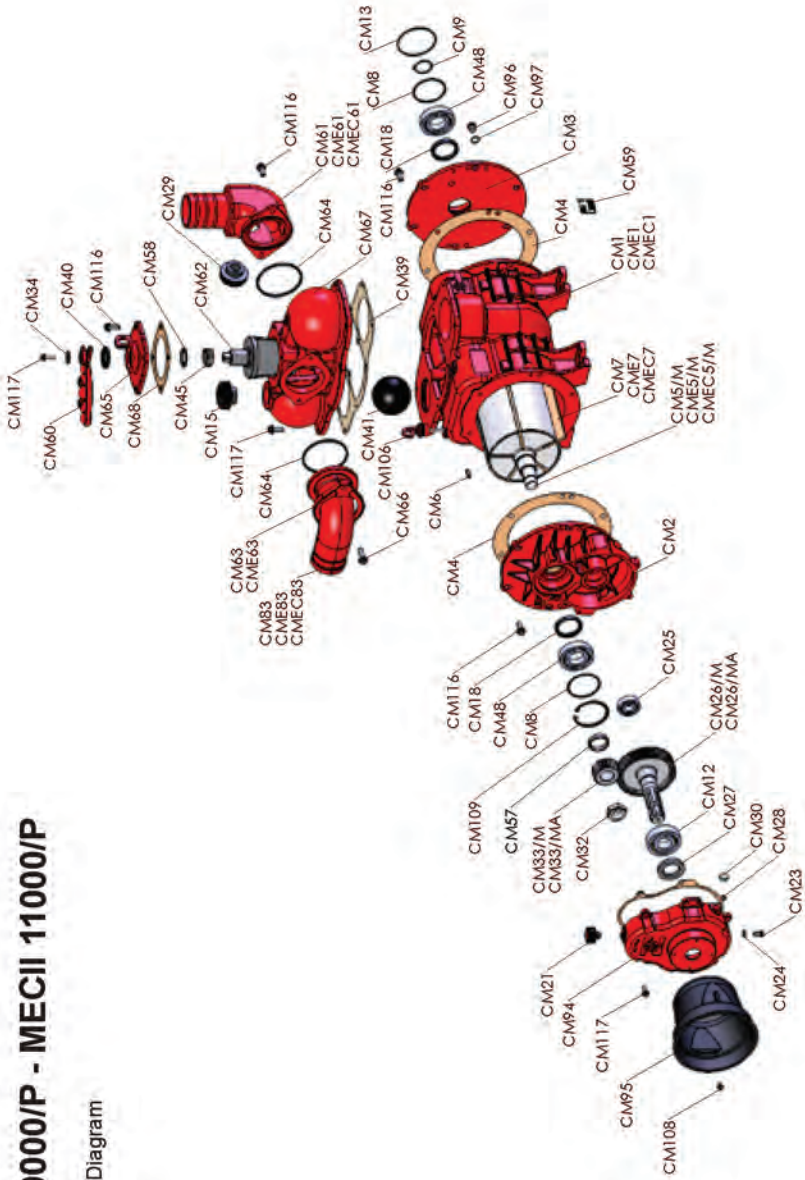

ITEM	PART NUMBER	DESCRIPTION
CM1	4010101085	MEC 9000, PUMP BODY
CM1E1	4010101086	MEC 11000, PUMP BODY
CM2	4010301028	GEARBOX
CM3	4010401061	FRONT FLANGE AND BACK FLANGE
CM4	4010308048	FLANGE GASKET
CM5/P	4010220147	MEC 9000, ROTOR
CM5E/P	4010220148	MEC 11000, ROTOR
CM6	5050707002	KEY
CM7	4070113192	MEC 9000, LONG LIFE BLADE
CM7E	4070113193	MEC 11000, LONG LIFE BLADE
CM8	5012207001	UNDULATED RING
CM9	5050507017	SEEGER RING
CM12	5012107010	BALL BEARING
CM13	5030210028	SEAL RING
CM15	5060605006	BLACK PLUG
CM18	5030300041	OIL SEAL
CM21	5060605001	OIL PLUG
CM23	5050107018	SCREW
CM24	5050202002	ALUMINIUM WASHER
CM25	5012107006	BALL BEARING
CM27	5030300005	OIL SEAL
CM28	4030108049	GEARBOX COVER GASKET
CM29	5060605005	BLACK PLUG
CM30	5060105004	OIL LEVEL PLUG
CM32	5050300002	SELF-LOCKING NUT
CM34	5050207022	WASHER
CM39	4030108035	MANIFOLD GASKET
CM40	5030300015	OIL SEAL

ITEM	PART NUMBER	DESCRIPTION
CM41	5060410007	HEAVY RUBBER BALL
CM45	4012007011	SPRING
CM48	5012107004	BALL BEARING
CM57	4011707067	ROTOR SPACER
CM58	5050207031	SMOOTH WASHER
CM59	5101800000	STICKER THERMO LABEL
CM60	4010801024	HANDLE
CM61	4011501031	SUCTION ELBOW, MEC 9000
CM61E1	4011501032	SUCTION ELBOW, MEC 11000
CM62	4010701016	REVERSING GEAR
CM63	4010406071	SUPPORT FLANGE, MEC 9000
CM63E3	4010406015	SUPPORT FLANGE, MEC 11000
CM64	5030210008	SEAL RING
CM65	4010601056	MANIFOLD COVER
CM66	5050107054	SCREW
CM67	4010501026	MANIFOLD
CM68	4030108025	MANIFOLD COVER GASKET
CM83	4010901018	REVOLVING ELBOW, MEC 9000
CM83E3	4010901019	REVOLVING ELBOW, MEC 11000
CM94	4010601154	GEARBOX COVER GASKET
CM95	4060505000	SHAFT GARDE
CM96	50509068006	IRON PLUG
CM97	5050202007	ALUMINIUM WASHER
CM106	5060100001	OIL LEVEL ROD
CM108	5050107107	SCREW
CM109	5050507011	SEEGER RING
CM116	5050107109	SCREW
CM117	5050107108	SCREW

MECII 11000

Ballast Check Valve As

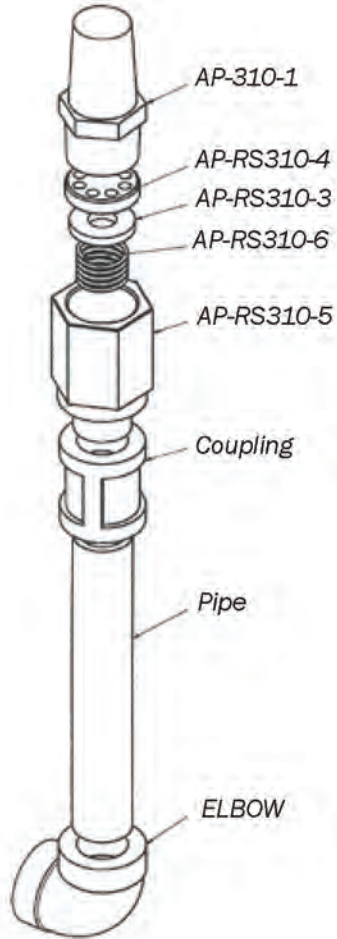

MECII 11000

Part #	Description
AP-310-1	Filter, 3/4" NPT
AP-RS310-4	Vent
AP-RS310-3	Washer
AP-RS310-6	Spring
AP-RS310-5	Body, Ballast Port Check
Coupling	Coupling - 1/2" NPT
Pipe	Pipe Nipple, 1/2" NPT x 5"
Elbow	Elbow - 90 Deg 1/2" NPT

Automatic Lubrication System

MECII 9000/P
MECII 11000/P

See Parts Diagram opposite.

Part #	Description
AM13	Gasket
AM49	Fitting
LB1	Bearing Cover -
LB8	Screw
LB11	Hose (4mm x 6mm x 10.25")
LB16	Hose (2mm x 4mm x 27.25")
LB17	Hose (2mm x 4mm x 11.5")
LB18	Clip
LF8	Drive Tab
LW32D	Piston Lubricator - Double Outlet (Clockwise)
LW32S	Piston Lubricator - Double Outlet (Counterclockwise)
R3	Fitting
R15	Fitting
R31	Gasket
R33	Washer
R34	Bolt
R35	Fitting
R36	Fitting
R37	Fitting
R37-1	Fitting

Detail
Automatic Lubrication System
MECII 9000/P • MECII 11000/P

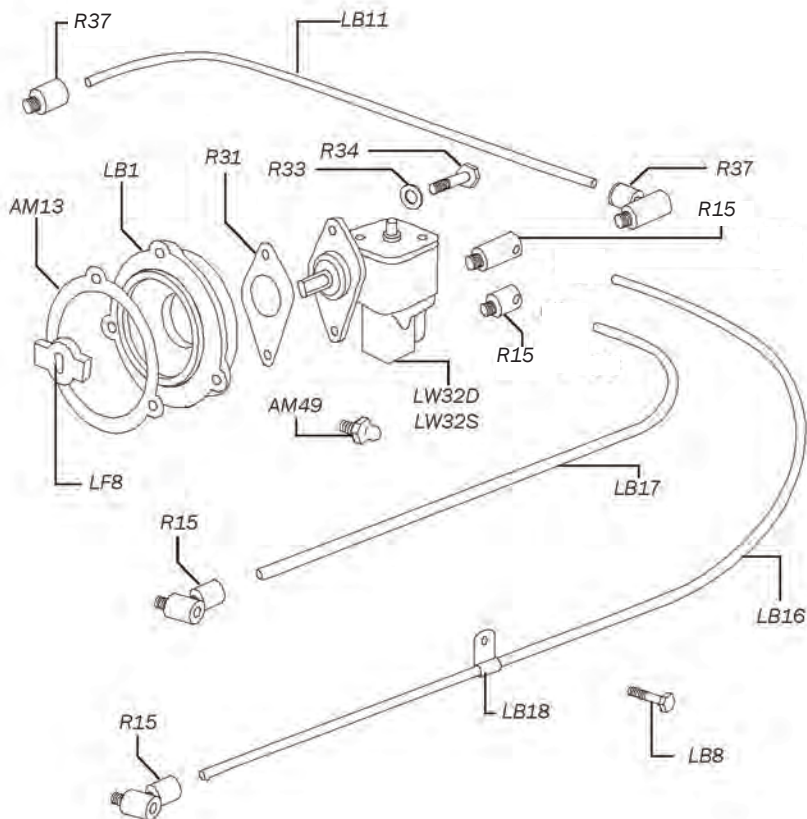

Automatic Oil Pump

See Parts Diagram opposite.

Part #	Description
P 1CW	Pump Body – 1 outlet (Clockwise)
P 1CCW	Pump Body – 1 outlet (Counterclockwise)
P 2CW	Pump Body – 2 outlet (Clockwise)
P 2CCW	Pump Body – 2 outlet (Counterclockwise)
P 5	Driven Gear (Clockwise)
PA 5	Driven Gear (Counterclockwise)
P 6	Spring
P 7CW	Driving Gear (Clockwise)
P 7CCW	Driving Gear (Counterclockwise)
P 8	Seal
P 9	Plug
P 10	Retainer
P 11	Adjusting Screw
P 12	Gasket
P 13	Lid
P 14	Screw
P 15	Jam Nut
P 16	Cap

Detail

Automatic Oil Pump

One & Two Outlet Type

- Part # LW32CD Clockwise - One Outlet
 Part # LW32CS Counterclockwise - One Outlet
 Part # LW32D Clockwise - Two Outlets
 Part # LW32S Counterclockwise - Two Outlets

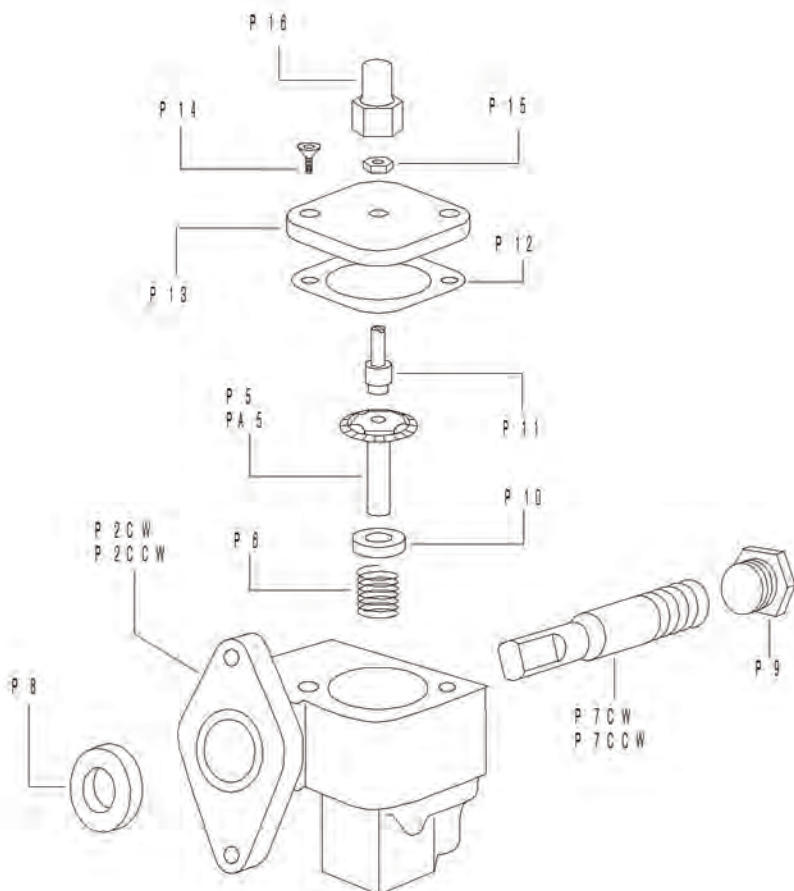

Gear-Type Lubrication System

MECII 9000/P

MECII 11000/P

See Parts Diagram opposite.

Part #	Description
AM13	Gasket
LF1	Cover Plate
LF2	Cover Plate Gasket
LF3	Drive Gear
LF4	Driven Gear
LF6	Bolt
LF7	Oil Pump Housing
LF8	Drive Tab
LF12	Dripper – T-Type (Clockwise)
LF12CCW	Dripper – V-Type (Counterclockwise)
LF12G	Dripper Gasket
LF12GL	Dripper Glass
LF13	Fitting (Housing Oil Reservoir - M10 x 1)
LF15	Hose (5mm x 10.5 mm x 6.75")
LF17	Fitting (Gear Type Oil Pump - M6 x 1)
LF19	Hose (5mm x 10.5 mm x 8.5")
LF20	Hose (5mm x 10.5 mm x 18.5")
LF21	Oil Line Per Foot
LF22	Oil Pump – Complete

