

NVE/F466 Pump

Owner's Record

Date of Purchase: _____

Purchased from: _____

Serial Number: _____



National Vacuum Equipment, Inc.

© 2003 National Vacuum Equipment, Inc.

0403

No part of this manual may be reproduced without the written permission of National Vacuum Equipment, Inc.

Contents

Introduction

About National Vacuum Equipment, Inc.	5
---	---

Limited Warranty

Warranty	7
Warranty Procedures	9

NVE/F466 Pump

Application	11
Pump Specifications	11
System requirements	12
Drive system	13
Direction of rotation	13
Factory Settings	13
Adjusting Factory Settings	14

Operating Instructions

Normal Operation	17
Lubrication System	18
Recommended Lubricant	18
Ballast Cooling	19
Maintenance	19
Cold Weather Operation	21

Troubleshooting

Pump overheats	23
Pump uses too much oil	23
Pump doesn't turn	23
No vacuum	24
System Troubleshooting	24
Making a vacuum tester	25

Table of Contents continues on next page.

Pump Rebuilding

Vane Replacement	27
Complete Rebuild	33

Parts List

Parts List	43
Oil Pump and Fittings — Detail	46
Ballast Port Check Assembly	48
Parts Diagram	49
Automatic Oil Pump Parts List and Diagram	50

Index

Introduction

General Information

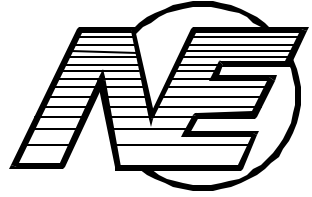

About National Vacuum Equipment, Inc.



Congratulations! You now own a quality vacuum/pressure pump proudly manufactured in the U.S.A. by National Vacuum Equipment, Inc. You have not only acquired a superior piece of equipment from a qualified dealer, you have hired a team of vacuum experts. We stand ready to work with your dealer to answer your questions and provide you with the information necessary to keep your equipment in peak working condition.

Thank you for using National Vacuum Equipment.

OUR MISSION:

We are dedicated to the manufacture and wholesale distribution of quality vacuum system products at a reasonable price, on a timely basis. We are a “one-stop shop” for manufacturers and distributors of vacuum equipment.

OUR HISTORY:

National Vacuum Equipment, Inc. was founded in 1980 by Bruce Luoma. The Company started as a retailer of vacuum pumps. Soon after it started, the Company secured the rights to exclusive distribution of the Battioni vacuum pumps in North America. This helped the Company to evolve into its current status as a wholesale supplier.

To reach the goal of becoming a full service supplier of vacuum system components, the Company began fabricating its own line of componentry, and developed its own line of vacuum pumps, high vacuum blowers and valves.

Today, NVE has full service machine and fabrication shops complete with CNC-controlled production equipment designed for close tolerance work. The company has a highly trained staff all of whom are dedicated to quality.

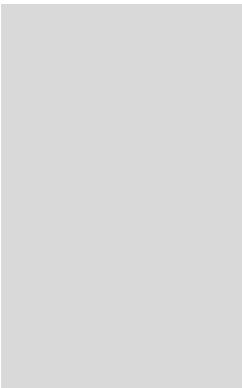

Limited Warranty

NVE/F466



National Vacuum Equipment, Inc.

guarantees that the product it provides is free of manufacturer's defects, including materials and workmanship. Properly installed and maintained product is warranted for a period of one (1) year subject to the following conditions:

1. A properly completed warranty registration card must be received by us within 30 days of sale to end user for pump sales to be considered warrantable. All pumps received for warranty consideration must retain the original NVE serial number tag.
2. The one (1) year period shall begin the day the product is shipped from our warehouse, unless we are provided with an authentic copy of the original resale invoice, in which case the one (1) year period shall begin at such invoice date.
3. The covered product must be used in an application for which it was intended. We do not recommend our product for particular uses or applications.
4. Vane breakage, or damage caused by vane breakage, is not warrantable.

5. Damage caused by improper use or lack of proper maintenance is not warrantable.
6. Manufacturer's liability under this or any other warranty, whether express or implied, is limited to repair of or, at the manufacturers option, replacement of parts which are shown to have been defective when shipped.
7. Manufacturer's liability shall not be enforceable for any product until National Vacuum Equipment, Inc. has been paid in full for such product.
8. Except to the extent expressly stated herein, manufacturer's liability for incidental and consequential damage is hereby excluded to the full extent permitted by law.
9. Manufacturer's liability as stated herein cannot be altered except in writing signed by an officer of National Vacuum Equipment, Inc.
10. Certain products provided by National Vacuum Equipment, Inc. are covered by their respective manufacturer's warranties (e.g., engines used in the NVE engine drive packages). These products are not covered by the National Vacuum Equipment, Inc. Manufacturer's Warranty.

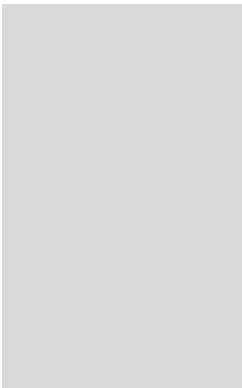

Should a potential warranty situation arise, the following procedures must be followed:

- Contact your dealer immediately upon the occurrence of the event and within the warranty period.
- Customer must receive a return goods authorization (RGA) before returning product.
- All serial-numbered products must retain the NVE serial number tag to be qualified for warranty.
- Product must be returned to NVE intact for inspection before warranty will be honored.
- Product must be returned to NVE freight prepaid in the most economical way.
- Credit will be issued for material found to be defective upon our inspection, based upon prices at the time of purchase.

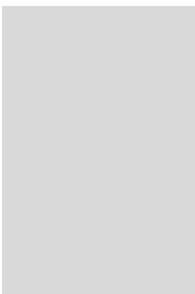

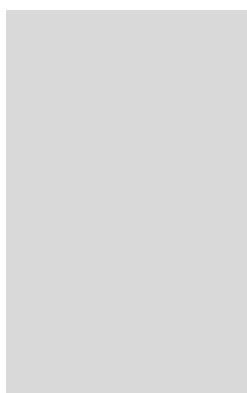

NVE/F466 Pump

Model-Specific Information



Application

Designed for extended operation

- The NVE/F466 is a severe duty vacuum pump, designed to be used in liquid waste pumping systems where extended operation is desired.
- This pump incorporates a ballast air and fan cooling system with full length cowling to provide superior cooling and allowing for extended operation.

Pump Specifications

NVE/F-466 PERFORMANCE

		PRESSURE P.S.I. (estimated)					VACUUM – INCHES OF MERCURY (estimated)										
RPM		25	20	15	10	5	0	3	6	9	12	15	18	21	24	27	
Intermittent operation only	1150	H.P.	49	43	36	27	23	18	20	21	22	23	24	25	26	28	29
		CFM	408	431	438	447	457	519	500	470	458	453	440	438	425	404	351
	1000	H.P.	43	38	32	24	20	15	17	18	19	20	21	22	23	24	25
		CFM	355	375	381	389	398	452	435	409	399	394	390	381	370	352	306
	850	H.P.	36	32	25	19	15	13	14	14	15	16	17	18	19	20	21
		CFM	302	319	324	331	342	385	374	348	339	333	331	324	315	303	242



Recommended Setup
for optimum performance

System requirements

High quality components

- The NVE/F466 is a high performance vacuum pump and requires compatible, high quality components.

Shutoffs

- We recommend the use of our Parts F-802C portal/portal shutoff, and our Part # F-901-C, 12 gallon scrubber/secondary shutoff.

Final filter

- We also require the use of a final filter. You can use our remote mounted filter (Part # F-1001C).

Hose

- Use 4" or larger hose to plumb your system. We recommend you use a hose that can withstand high temperatures such as hot tar-asphalt hose.

Pressure relief and vacuum relief valves

- A pressure relief valve and vacuum relief valve should also be incorporated in the system.
- The pressure relief valve should be set for a maximum of 25 p.s.i. or as allowed by the tank manufacturer if lower.
- The vacuum relief valve should be set for 20" Hg.
- The relief valves should be set to where the pump operates at a maximum temperature of 350° F.

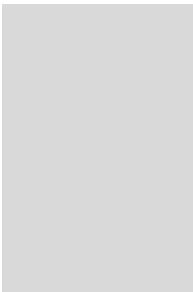

Drive system

- The pump should be mounted on a level, horizontal surface, secured with grade 5 or better fasteners.
- The drive system should be sized to supply the required horsepower to the pump plus a reserve to insure long life.
- Make certain that all shafts, pulleys or turning parts are properly guarded.
- Check the ratio of the drive system prior to installation to verify that the pump will be turning at the proper speed and direction.
- The pump should be set up to engage slowly to avoid initial torque damage.

Direction of rotation

- The direction of rotation and RPM are marked on the front of the pump.
- The direction of rotation required by your drive system should be determined prior to ordering the pump.
- If during assembly of your unit you find you need the opposite rotation, call the factory for instructions.

Factory Settings

- The automatic oil pumps are set at the factory during pump testing and should require no further adjustment during pump installation.
- The pumps are adjusted to one drop every two seconds per outlet. This oil rate equals 2.7 fluid oz. per hour, or Approximately 8hr./Gal. The tank capacity is 1 Gal.

Adjusting Factory Settings

The automatic oil pump is a metered piston-type pump.

If you wish to adjust the pump, please follow these instructions:

Adjusting the oil rate

Oil flow is changed by adjusting the length of the stroke of the piston, located behind the oil tank

1. To adjust the oil rate, remove cap #P16. Under this cap you will find a jam nut #P15 and adjusting screw #P11.
2. To adjust oil rate loosen jam nut and turn adjusting screw clockwise to reduce oil flow or counterclockwise to increase oil flow.
3. When making adjustments do so one turn of the screw at a time and test before making further adjustments.
4. Be careful to not turn adjusting screw too far counterclockwise as you may disengage the gears and strip them out.

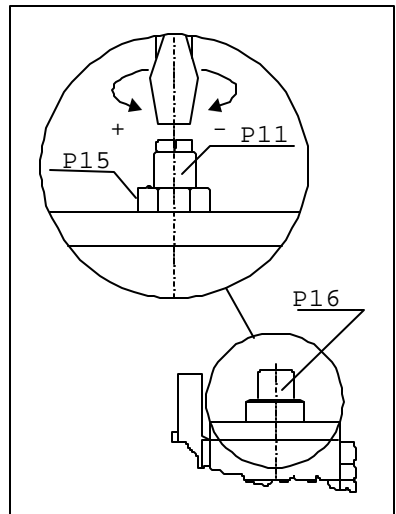

Testing flow rate after adjustment

1. Observe oil drip rate by disconnecting an oil line and watching for the proper lubrication rate, in drops per minute (30).
2. Adjustments should be done gradually so as not to starve the vacuum pump of oil.
3. Each side of the oil pump must be checked and adjusted separately.

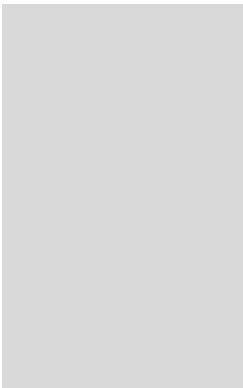

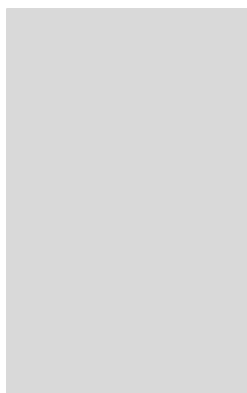

Operating Instructions

NVE/F466



Normal Operation

Maintenance

- Fill oil reservoir to the top daily or more often as required.
- Drain and flush oil tank with diesel fuel as required.
- Clean the ballast air filter with diesel fuel regularly.

Recommended R.P.M.

- Do not operate the pump faster than the recommended R.P.M. See chart on page 11.

Suction valve

- To operate the suction valve, move the handle in the appropriate direction for either vacuum or pressure; center is neutral.

Vacuum levels

- Do not operate your pump for extended periods of time at vacuum levels exceeding 25" Hg. Maximum continuous vacuum depends on filter condition, R.P.M., ambient temperature, and altitude. Do not operate the pump at temperatures exceeding 375° F.

Higher Altitude	=>	Higher Heat
Higher Vacuum	=>	Higher Heat
Higher R.P.M.	=>	Higher Heat
Higher Ambient Temp.	=>	Higher Heat
Dirty Filters	=>	Higher Heat

Guards

- Make certain all guards are in place prior to running your pump. Think safety!

Lubrication System

Force feed system

- The NVE/F466 is supplied with a force feed type lubrication system which incorporates a piston type pump and three-point oiling.

The drip rate is preset at the factory.

- If any adjustments are required please see “Adjusting Factory Settings” on page 14.

Recommended Lubricant

- We recommend that turbine oil be used in our pumps. Turbine oil is much more resistant to breakdown due to heat than normal motor oil, thereby avoiding the problems associated with motor oil, such as lacquering and excessive wear.

- Acceptable oils:
 Penzoil Penzabell 68 T.O.
 Shell Turbo 68
 Mobil D.T.E. Heavy – Medium
 Texaco Regal R. & O. 68

Ballast cooling

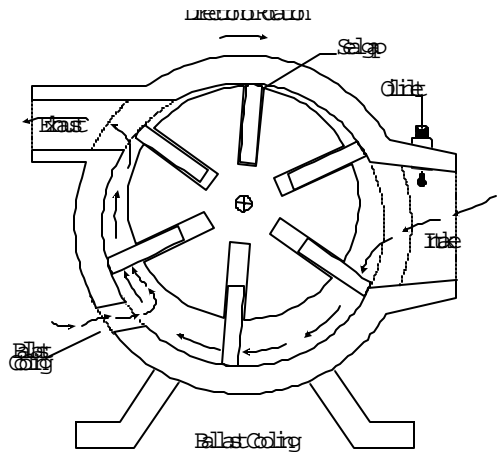

- Ballast cooling of a vacuum pump is accomplished by introducing atmospheric air into the exhaust side of the pump housing. The ballast inlet is located at a point where the affected pump cell is no longer in contact with the intake port.
- The result is cooling of the housing and rotor with no appreciable drop in vacuum level.

Maintenance

Washing

- Periodically wash the mud and dirt off your pump. The NVE/F466 is an air cooled pump. It must be clean to allow heat to radiate from it. Regularly clean and inspect the ballast air filter. Also drain and clean the oil tank as necessary.

Flushing

We recommend periodic flushing of your pump. To do this:

1. Connect a hose barb and hose to the flush valve located on the side of the inlet port.
2. Put the end of the hose in a one pint container of diesel fuel. Start your pump and run as slow as possible.
3. With the 4-way valve in the vacuum position, open the flush valve and monitor the diesel flow to your pump.
4. When the diesel fuel is gone switch the 4-way valve to neutral and run the pump for 2 minutes.
5. Speed the pump up to normal R.P.M., switch the 4-way valve to vacuum.
6. Close the valve, remove the hose.
7. Properly dispose of used oil and flushing fluid.

Checking vane wear – overview

- We recommend checking vane wear at least every 12 months.
- A new vane is flush with the outside diameter of the rotor.
- Remove the plug from the vane check port, insert a rod to rotor O.D., rotate rotor until the rod falls into one of the vane slots. If the rod falls more than a 1/4" into any of the 6 vane slots, it is time to replace the vanes.
- Vanes should be replaced in sets and it is always a good idea to have an extra set of vanes on hand for emergencies.



Cold Weather Operation

Confirm pump is not frozen.

- Prior to engaging the pump, turn by hand to confirm it is not frozen.

If pump is frozen, thaw it.

- If the pump is frozen, thaw it out by heating the bottom of the pump with a torch or move the truck into a heated building.

Avoid freezing problems.

- You can avoid freezing problems by putting a small amount of diesel fuel into the pump at the end of the day.

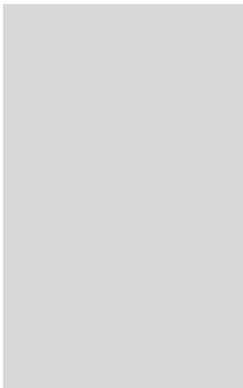

Troubleshooting

NVE/F466 Pump



Pump overheats

- No oil in pump
- Oil adjustment set too lean
- RPM too fast
- Prolonged operation at excessive vacuum or pressure levels
- Pump dirty
- Ballast filter dirty

Pump uses too much oil

- Oil pump set too rich; see operating instructions
- Leaving vacuum on tank while moving from job to job

Pump doesn't turn

- Broken vane or bearing
- Frozen
- Problem in the drive train

No or Low Vacuum

- Suction valve in neutral
- Worn seals or vanes
- Pump not turning fast enough
- Check valve or suction valve clogged
- Leak in tank or fittings
- Collapsed hose between pump & shutoffs

System Troubleshooting—Locating the source of the trouble

If you notice a decrease in pumping performance, start troubleshooting at the pump.

1. Remove the suction and discharge hoses at the pump.
2. Start the pump and run it in vacuum only at its normal rpm.
3. Check the vacuum level at the pump inlet. The NVE/F466 in new condition will develop 27-28" Hg.
4. If the pump checks out OK, check the vacuum level at the secondary, then the primary shutoff. Keep working your way back until you find the problem.

Making a vacuum tester

1. Procure a flange to mount on your four-way valve, a short 4" pipe nipple, a 4" pipe cap and a vacuum gage.
2. Drill and tap a 1/4" N.P.T. thread in the pipe cap.
3. Assemble the flange, nipple, pipe cap and vacuum gage.
4. Remove a flange from the four-way valve on your pump.
5. Start the pump and confirm the location you have chosen to test from is at vacuum.
6. Using the existing O-ring, fasten the testing flange to your pump.
7. Start your pump and read the vacuum level on the gauge.

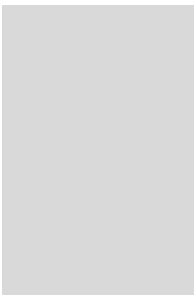

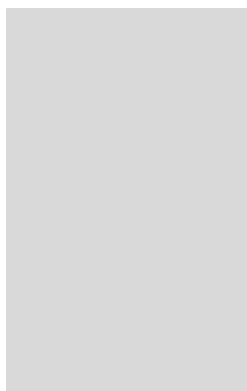

Pump Rebuilding

NVE/F466 Pump

Please read these instructions completely before attempting repair.

There are two types of pump repair—vane replacement and total rebuilding.

Vane Replacement



1. Clean off the exterior of the pump, drain and remove oil tank, clean the inside if necessary.



2. On the oil tank end, loosen the shroud by removing the button head cap screw on the top of the shroud that attaches it to the end plate.



3. Remove the oil lines from the oil pump mount that go under the pump shroud.



4. Remove the four hex head bolts that attach the oil pump mount to the vacuum pump and remove oil pump and pump mount assembly.

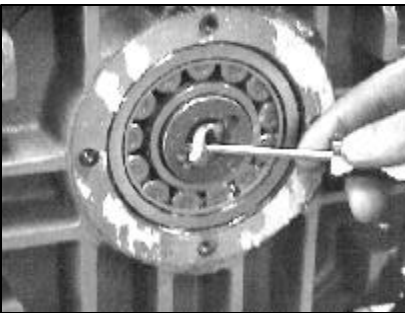

5. Remove the oil pump drive key from the end of the rotor.



6. Remove the six hex head screws that hold the end plate in place and pull the end plate off. It may be necessary to push off the end plate using bolts (as jack screws) in the two tapped holes provided.

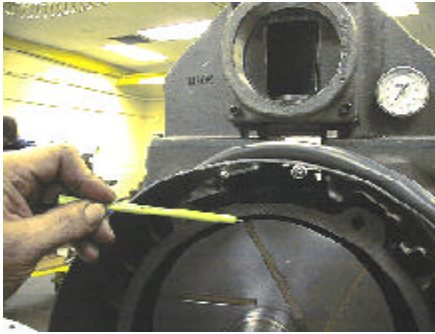

7. Inspect vanes, bearings and seals and replace as necessary.

A new vane is flush with the outside diameter of the rotor.

If they are worn more than 1/4" they should be replaced.

We recommend replacing vanes in sets.

If the ends of the vanes are chipped or delaminated they should be replaced.

The seals should be soft and pliable.

The bearing should turn smoothly.



8. Coat the vanes with oil and install the vanes in the rotor. Ensure that the vanes are properly installed, the angle of the vane should match the outside of the rotor and not extend past the O.D. of the rotor. mamatchup with the outside diameter of the rotor.



The vanes should slide freely in the vane slot.



9. Locate two 3/8-16 x 2-1/2 Lg. studs and insert them into the bolt holes on either side of the endplate



10. Lubricate seal sleeve and install the same number of end plate gaskets as were removed.



11. Align the endplate onto the dowel pins and bolt into place. Tighten endplate bolts to 35-40 ft. lbs of torque



15. Connect the oil line to the oil pump mount assembly from the front of the pump.
16. Reinstall the oil tank and fill the pump with oil. The pump is now ready to run. At this point the pump should turn freely by hand.



17. Start the pump at a slow R.P.M. and allow to run for a few minutes until the oil fills the oil lines and can get to the bearings.

The pump is now ready to go to work.

Complete Rebuild



1. Follow steps 1- 6 in the vane replacement instructions.

2. Remove the vanes from the pump.



3. Place a cushion under the rotor to prevent damage when the front endplate is unbolted, because the rotor will drop.



4. From the drive end, remove the four screws that attach the fan cover to the shroud.



Remove the fan by loosening the clamping bolt and spreading the clamping collar with a screw driver or chisel.



5. Remove the three button head screws that attach the steel shroud to the aluminum shroud.



6. Remove the four bolts attaching the aluminum shroud to the endplate and remove the shroud.

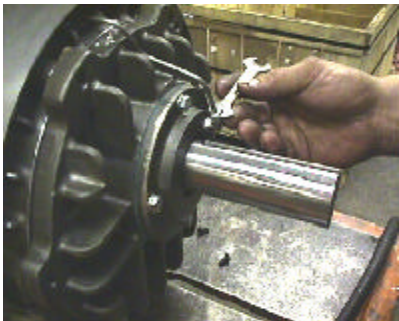

7. Remove the oil line to the drive end bearing.

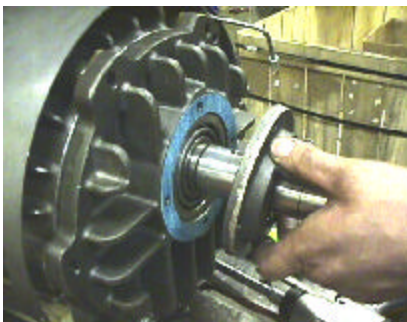

8. Remove the bearing cover.

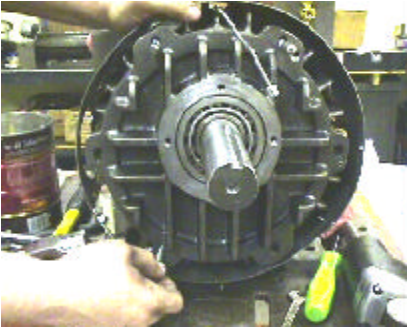

9. Remove the two remaining bolts attaching the endplate to the housing.

Support the rotor shaft prior to loosening the last bolt.

Slide the rotor out.



10. Remove the front endplate by sliding it off the end of the shaft.

Put an identifying mark on the endplate so as to not confuse it with the rear.

Count the number of gaskets.



11. Clean the rotor, rotor slots and housing and inspect for wear or damage also check the seal sleeves for groves.

If the housing needs to be bored or honed, remove only as much material as is necessary to give a smooth clean bore.

The maximum overbore we recommend is .060 inch. A new housing has a bore of 10.000 inches.

If you bore or hone the housing, remove the four-way valve assembly and internal check valve prior to machining.

If the housing is bored, the top seal gap must be reset and the dowel pins can not be used.

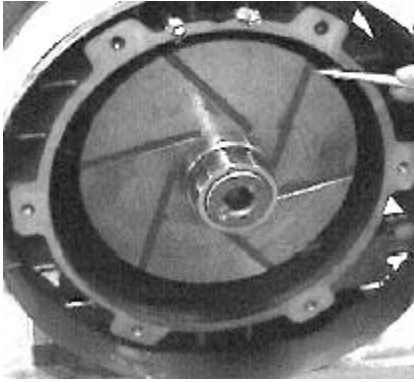

12. Inspect vanes, bearings and seals and replace as necessary.

A new vane is flush with the outside diameter of the rotor.

If they are worn more than 1/4" they should be replaced.

We recommend replacing vanes in sets.

If the ends of the vanes are chipped or delaminated they should be replaced.

The seals should be soft and pliable.

The bearing should turn smoothly.



13. Locate the replacement seals and install them in the endplates with the seals positioned back to back.

Replace the seals in the bearing cover with the seals back to back or springs to the outside and lubricate.



14. Lubricate and install the bearings in the endplates.

15. Locate two pieces of threaded rod 3/8–16 thd. to use as guides and screw them into the two top holes in the housing.

Locate the gasket and slide it on the threaded rods and pins.

Do not use any gasket sealer.



16. Lubricate the housing bore.

17. Lubricate seal sleeve and slide the proper endplate on the input end of the rotor.

Install the endplate and slide rotor-endplate assembly into the pump housing.

Slide the cushion material (used during disassembly) under the rotor on the opposite end to gain leverage during assembly of endplate to housing.





18. Lift the rotor-endplate assembly and slide over the 3/8 inch threaded guides and pins and install the endplate bolts.

Tighten the bolts sufficiently to make contact between the endplate and the housing.

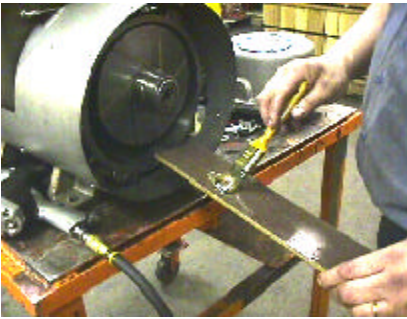

19. Coat vanes with oil and install the vanes in the rotor. The vanes should slide freely in the vane slots.

20. Locate the correct number of gaskets and install them on the rear endplate.

Do not use any gasket sealer.



21. Lubricate seal sleeve and install the endplate on the end of the rotor.



22. When the endplate is close enough to the housing, install the endplate bolts.

Lift the endplate-rotor assembly to allow proper alignment of the bolts, pins and bolt holes and start the bolts into the housing.

Tighten endplate bolts to the point where the endplate just touches the housing. If the pump has been bored.

23. Use a prybar and a block of wood, lift the endplate to make certain the seal gap is properly set.

Tighten the endplate bolts to 35–40 ft. lb. of torque. Tighten both endplates in this manner.



24. At this point you should be able to turn the pump by hand. If the rotor does not turn easily the bearings may have to be “set” by hitting the O.D. with a bearing driver.



25. Lubricate the seal surface on the rotor and reinstall the front bearing cover.

Coat the gasket with a hardening gasket sealer.

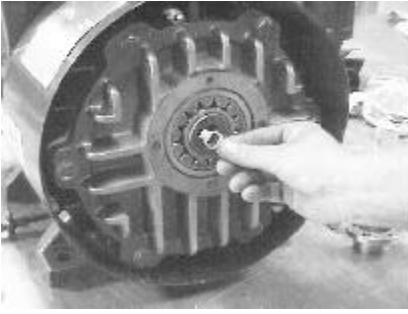

26. Reinstall the oil pump drive key and oil tank mount-oil pump assembly.



27. Be sure to line up the oil pump drive key and the oil pump shaft prior to tightening the assembly to the pump.

Use gasket between the assembly and the endplate.

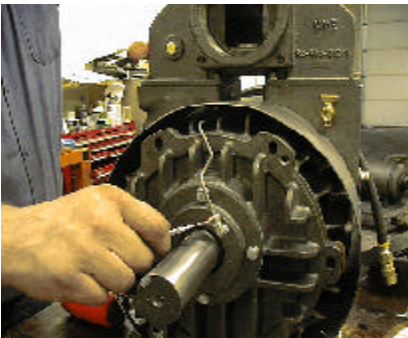

28. Reassemble to oil line to the front endplate.

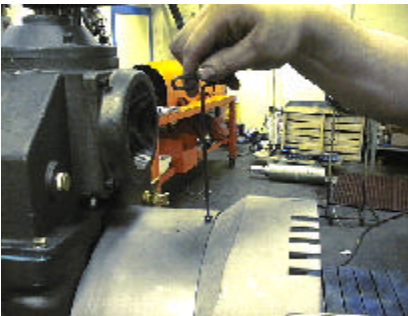

29. Attach the steel shroud to the shroud support and aluminum shroud using the button head screws.



30. Connect the oil line to the oil pump mount assembly from the front of the pump.

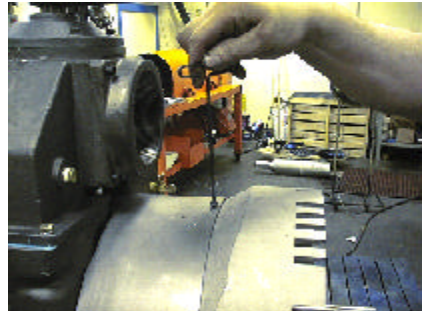

31. Slide the fan on the input shaft.

Tighten the clamping bolt in the hub.

Make sure there is sufficient clearance to mount the fan cover and allow clearance for the oil line when positioning the fan assembly.



32. Reassemble the fan cover to the fan shroud.

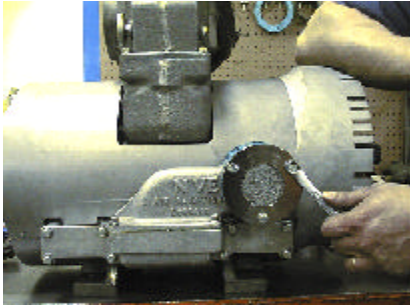

33. Remove the Ballast filter, Inspect for dirt or damage. clean as required or replace the filter.



34. Reinstall the oil tank and fill the pump with oil.

The pump is now ready to run.



35. Start the pump at a slow R.P.M. and allow to run for a few minutes until oil can work it way to the bearings.

Allow the pump to run for a few more minutes.

The pump is now ready to go to work.

NVE 466 Challenger Parts List

See Parts Diagram Foldout on page 49.

Key	Part #	Description
	466-0	Repair Kit
	466-0B	Repair Kit w/o Bearings
1	BT29	BHCS 1/4-20 x 5/8 Lg.
1A	B7-0505	BHCS 5/16-18 x 5/8 Lg.
2	460-66-1	Fan Cover
3	466-63CW	Fan Assembly (CW)
3	466-63CCW	Fan Assembly (CCW)
3A	B2-5510	SHCS 5/16-24 x 1-1/4 Lg.
4	466-65-1	Fan Shroud
5	B1-0507	HHCS 5/16-18 x 7/8 Lg.
6	B8-0503	Lock Washer 5/16
7	460-54	Bearing Cover
8	460-53V	Seal - Viton (45-62-8)
9	460-18V	Seal - Viton (65-85-8)
10	466-60-B	Lower Shroud
11	466-60-T	Upper Shroud
12	460-13	Gasket
13	460-W93	Bearing
14	360-LP51	Oil Fitting (4mm tube x 1/8" NPT 90° Elbow)
14A	360-LP56	Oil Fitting (4mm tube x 1/8" BSPT 90° Elbow)
15	B1-0610	HHCS 3/8-16 x 1-1/4 Lg.
15A	B1-0616	HHCS 3/8-16 x 2 Lg.
15B	B2-0606	SHCS 3/8-16 x 3/4 Lg.
16	B8-0601	Washer 3/8
17	466-3D	Front End Plate (Right Hand Turning)
17	466-3S	Front End Plate (Left Hand Turning)
18	400-7	Vane
19	460-5CW	Rotor (Clockwise)
19	460-5CCW	Rotor (Counterclockwise)
19A	460-9	Seal Sleeve
20	LF8	Pump Drive Tab

Key	Part #	Description
21	466-4	End Plate Gasket
22	466-1	Pump Housing
23	460-LP1A	Oil Tank Mount
24	360-LP13	O-Ring
25	R31	Gasket
26	LW32AD	Oil Pump (Clockwise)
26	LW32AS	Oil Pump (Counterclockwise)
27	360-LP55	Oil Fitting (4mm tube x 1/8" BSPT)
28	B1-0512	HHCS 5/16-18 x 1-3/4 Lg.
29	460-LP93	Oil Line
30	350-LP1	Oil Tank
31	P1-1200	Plug 3/4 NPT Soc. Hd.
32	B2-0507	SHCS 5/16-18 x 7/8 Lg.
33	360-LP11V	Plug Vented 3/4 NPT hex. hd.
34	460-LP97	Oil Line (Counterclockwise)
35	460-LP91	Oil Line (Clockwise)
36	B2-0405	SHCS 1/4-20 x 5/8 Lg.
37	460-LP90	Oil Line
38	360-LP50	Oil Fitting (4mm tube x 1/8" NPT)
39	BT21-460	Shroud Support 460
39A	B3-0410	SHSS 1/4-20 x 1-1/4 Lg.
40	P9-0812P	Dowel Pin, 1/4 x 1-1/2 pull pin
41	460-LP96A	Oil Line (Counterclockwise)
42	466-LP95	Oil Line (Clockwise)
42	460-LP95A	Oil Line (Counterclockwise)
43	460-39	Gasket flange
44	460-311	Exhaust check poppet
45	460-311/R	Check Retainer
46	B2-0510	SHCS 5/16-18 x 1-1/4 Lg.
47	460-312-4/F	Valve Flange
48	460-312-4F0	O-Ring 2-158 Viton
49	B1-0507-GR8	HHCS 5/16-18 x 7/8 Lg. Gr. 8
49A	N9	Nut 5/16-18
49C	B3-0512	SHSS 5/16-18 x 1-1/2 Lg. Cup Pt.
50	460-312-4/H	Valve Housing
51	460-312-4/TG	Gasket
52	460-312-4/T	Valve Top
54	460-312-4/RH	Handle
55	WA9	Washer
56	B1-0608	HHCS 3/8-16 x 1 Lg.
57	B2-0507	SHCS 5/16-18 x 7/8 Lg.

Key	Part #	Description
58	460-63F-5	Key 3/8 x 3/8 x 1
59	AP-312-4/S	Seal 1-3/16 x 1-11/16 x 5/16
60	AP-312-4/SP	Spring 4" 4-way
61	460-312-4/P	Valve Plug 4" 4-way
62	460-6	Key 3/8 x 3/8 x 2
63	A-20025D00962	Thermometer 2-1/2" Dia. 400° F
64	P2-1200-SE	Plug 3/4 NPT sighteye
65	P2-0400-B	Plug 1/4 NPT Hex Hd. Brass
66	460-3	Valve 1/8 NPT petcock
67	466-LP96	Oil Line (Clockwise)
67	466-LP96A	Oil Line (Counterclockwise)
68	BT28	Screw #6 x 1/2 Lg.
69	466-310-1	Manifold lower ballast
69A	466-310-4	Gasket lower ballast mfd.
69B	B1-0526	HHCS 5/16-18 x 3-1/4 Lg.
70	466-310-2	Elbow, ballast
70A	466-310-5	Gasket, Elbow
70B	B2-0507-S	SHCS 5/16-18 x 7/8 18-8 stainless
70C	B8-0503-S	Lock Washer 5/16 18-8 stainless
71	466-310-3R	Rear cover, ballast check
71A	466-310-6	Gasket, ballast covers
71B	B1-0506-S	HHCS, 5/16-18 x 3/4 18-8 stainless
72	AP-311-3/S	Spring, 360 check valve
73	466-310-7	Poppet, ballast check
74	466-310-3F	Front cover, ballast
75	466-310-8	Filter, ballast
76	466-310-3FC	Filter cover, ballast
77	466-310-3FA	Air scoop, ballast
77A	B1-0511-S	HHCS, 5/16-18 x 1-3/8 18-8 stainless
78	466-66-H	Hydraulic Mount
79	460-LP92	Oil Line (Clockwise)
80	Open
81	460-LP97	Oil Line (Clockwise)

Oil Pump and Fittings (Clockwise) — Detail

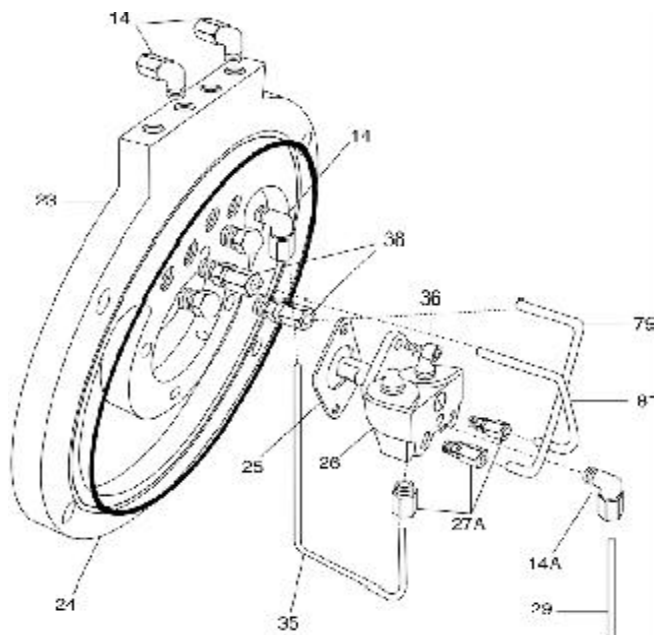

Oil Pump and Fittings (Counterclockwise) — Detail

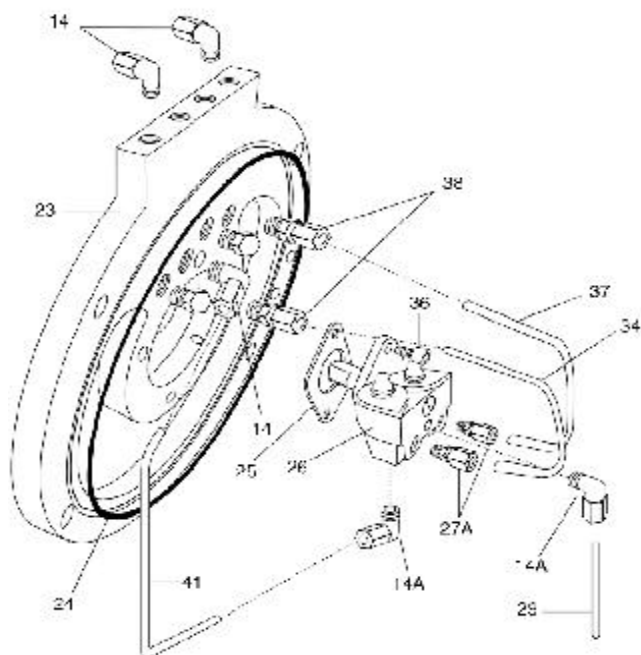

Remove and replace with parts diagram foldout

Remove and replace with parts diagram foldout

