

MEC 1000/P
MEC 1600/P

Owner's Record

Date of Purchase: _____

Purchased from: _____

Model: _____

Serial Number: _____

© 1999 National Vacuum Equipment, Inc.

No part of this manual may be reproduced without the written permission of National Vacuum Equipment, Inc.

Contents

Introduction

About National Vacuum Equipment, Inc.	5
---	---

Limited Warranty

Warranty	7
Warranty Procedures	9

The MEC Series Pumps

Pump Specifications	11
Performance	12
System requirements	13

Operating Instructions

Installation	15
Lubrication procedure	16
Automatic oil pump	16
Adjusting the automatic oil pump	17
Recommended lubrication	18
Normal operation for air cooled pumps:	18
Maintenance	19
Determining the rotation of the pump	20

Troubleshooting

Pump overheats	21
Too much oil use	21
Pump doesn't turn	21
No vacuum or pressure in tank	22

Pump Rebuilding

Vane replacement	23
Complete rebuild	29

Table of Contents continues on next page.

Parts List - MEC /P Series Pumps

Parts List	35
Parts Diagram	36

Parts List - MEC /540 Series Pumps

Parts List and Diagram	38
------------------------------	----

Parts List - MEC Mixer Valve Manifold

Parts List and Diagram	39
------------------------------	----

Parts Details - Lubrication Systems

Automatic Lubrication System	40
Automatic Oil Pump	42
Gear-Type Lubrication System	44

Index

Introduction

NVE

General Information

About National Vacuum Equipment, Inc.



Congratulations! You now own a quality vacuum/pressure pump exclusively distributed in North America by National Vacuum Equipment, Inc. You have not only acquired a superior piece of equipment from a qualified dealer, you have hired a team of vacuum experts. We stand ready to work with your dealer to answer your questions and provide you with the information necessary to keep your equipment in peak working condition.

Thank you for using National Vacuum Equipment.

OUR MISSION:

We are dedicated to the manufacture and wholesale distribution of quality vacuum system products at a reasonable price, on a timely basis. We are a “one-stop shop” for manufacturers and distributors of vacuum equipment.

OUR HISTORY:

National Vacuum Equipment, Inc. was founded in 1980 by Bruce Luoma. The Company started as a retailer of vacuum pumps. Soon after it started, the Company secured the rights to exclusive distribution of the Battioni vacuum pumps in North America. This helped the Company to evolve into its current status as a wholesale supplier.

To reach the goal of becoming a full service supplier of vacuum system components, the Company began fabricating its own line of componentry, purchased and developed its own line of vacuum pumps, and began purchasing for resale various valves and accessories.

Today, NVE has full service machine and fabrication shops complete with CNC-controlled production equipment designed for close tolerance work. The company has a highly trained staff all of whom are dedicated to quality.

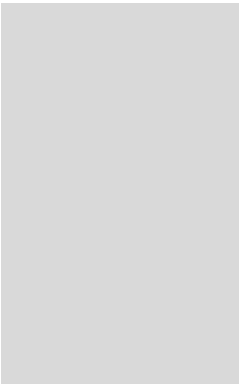

MEC 1000/P
MEC 1600/P



National Vacuum Equipment, Inc.

guarantees that the product it provides is free of manufacturer's defects, including materials and workmanship. Properly installed and maintained product is warranted for a period of one (1) year subject to the following conditions:

1. A properly completed warranty registration card must be received by us within 30 days of sale to end user for pump sales to be considered warrantable. All pumps received for warranty consideration must retain the original NVE serial number tag.
2. The one (1) year period shall begin the day the product is shipped from our warehouse, unless we are provided with an authentic copy of the original resale invoice, in which case the one (1) year period shall begin at such invoice date.
3. The covered product must be used in an application for which it was intended. We do not recommend our product for particular uses or applications.
4. Vane breakage, or damage caused by vane breakage, is not warrantable.

5. Damage caused by improper use or lack of proper maintenance is not warrantable.
6. Manufacturer's liability under this or any other warranty, whether express or implied, is limited to repair of or, at the manufacturers option, replacement of parts which are shown to have been defective when shipped.
7. Manufacturer's liability shall not be enforceable for any product until National Vacuum Equipment, Inc. has been paid in full for such product.
8. Except to the extent expressly stated herein, manufacturer's liability for incidental and consequential damage is hereby excluded to the full extent permitted by law.
9. Manufacturer's liability as stated herein cannot be altered except in writing signed by an officer of National Vacuum Equipment, Inc.
10. Certain products provided by National Vacuum Equipment, Inc. are covered by their respective manufacturer's warranties (e.g., engines used in the NVE engine drive packages). These products are not covered by the National Vacuum Equipment, Inc. Manufacturer's Warranty.

Should a potential warranty situation arise, the following procedures must be followed:

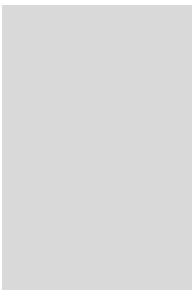

- Contact your dealer immediately upon the occurrence of the event and within the warranty period.
- Customer must receive a return goods authorization (RGA) before returning product.
- All serial-numbered products must retain the NVE serial number tag to be qualified for warranty.
- Product must be returned to NVE intact for inspection before warranty will be honored.
- Product must be returned to NVE freight prepaid in the most economical way.
- Credit will be issued for material found to be defective upon our inspection, based upon prices at the time of purchase.

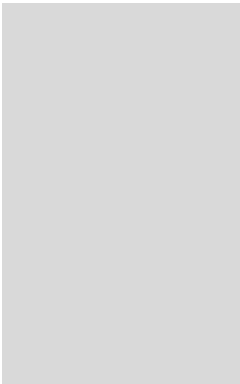

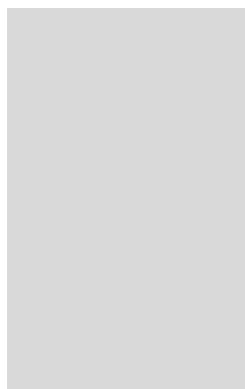

The MEC Series Pumps

*Model-Specific Information for the
MEC 1000/P
MEC 1600/P*



MEC Series Pump Specifications

<u>Model Number</u>	<u>1000</u>	<u>1600</u>
RPM Range	800–1400	800–1400
Max. Air Flow-CFM	46	72
Max. Continuous Vacuum	20	20
Max. Intermittent Vacuum	27	27
Max. Continuous Pressure	15	15
Max. Intermittent Pressure	30	30
Pump Drive Rotation	CW/CCW	CW/CCW
Porting Size	45 mm	45 mm
Manifold With Four Way Valve	Standard	Standard
Oil Tank Capacity-Quarts	2/3	3/4
Bearings Sealed From Pump Interior	Standard	Standard
Anti-Spin Check Valve	Standard	Standard
Suction Lubrication System	Standard	Standard
Net Weight	80 lbs	99 lbs

Performance

MEC1000/P PERFORMANCE

		PRESSURE PSI						VACUUM – INCHES OF MERCURY									
RPM		30	25	20	15	10	5	0	3	6	9	12	15	18	21	24	27
1400	HP	7	6	5	4	3	2	1	2	2	2	2	3	3	3	4	4
	CFM	13	15	20	26	32	38	46	43	40	38	36	33	27	23	14	3
1200	HP	6	5	4	3	3	2	1	1	1	1	2	2	2	3	3	-
	CFM	7	10	13	18	23	28	37	35	33	30	27	24	17	10	3	-
1000	H.P	5	4	3	3	2	1	1	1	1	1	1	2	2	2	2	-
	CFM	3	5	7	13	17	23	32	28	26	25	22	18	13	5	2	-

MEC1600/P PERFORMANCE

		PRESSURE PSI						VACUUM – INCHES OF MERCURY									
RPM		30	25	20	15	10	5	0	3	6	9	12	15	18	21	24	27
1400	HP	10	9	8	6	4	3	2	3	3	3	3	4	4	4	5	5
	CFM	37	42	50	53	58	65	72	70	68	65	63	60	55	50	44	35
1200	HP	8	7	6	5	3	2	1	2	2	2	2	2	3	3	4	4
	CFM	30	33	36	40	45	50	57	55	53	50	47	45	40	35	28	20
1000	H.P	7	6	5	4	3	2	1	1	2	2	2	2	20	3	3	-
	CFM	20	23	27	31	35	40	47	45	43	41	37	35	31	25	15	-



**Recommended Setup
for optimum performance**

System requirements

High quality components

- The pump body and rotor are constructed of cast iron with free sliding vanes made of special nonmetallic, heat resistant material.
- Because vanes are nonmetallic, flammable fluids may be handled without danger.
- Vanes wear evenly because tips always remain in contact with the wall surface.
- For maximum life and proper performance we recommend the use of our compatible components, Portal F-801-2E, Moisture Trap F-901-1E, and Oil Catch Muffler F-1002-5E.

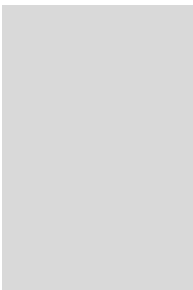

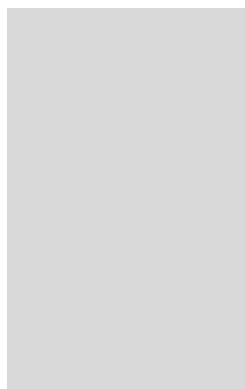

Operating Instructions

MEC 1000/P

MEC 1600/P



Installation

- Check pump rotation. See *Determining the Rotation of Pump*.
- Pump should always be mounted in a level, horizontal position on a firm, flat surface.
- Grade 5 bolts should be used in installation. It is important to use flat washers and lock washers.
- We recommend the use of oil resistant hose on both the inlet and outlet sides of the pump. If using direct drive system, always use a flexible coupling. We recommend the use of Woods Sure Flex Couplers.
- If a muffler is used on discharge side of pump, inlet and outlet of muffler must be at least equal to inside diameter of pump outlet.

Lubrication procedure for all vacuum pumps on start up

(This procedure must be followed prior to the operation of a new vacuum pump.):

- With force feed lubrication type, install dripper on top of pump and connect rubber lines.*
- Remove dipstick and fill oil reservoir with recommended turbine oil.
- With 540 RPM pumps: fill gear housing to level of clear plastic sight plug on the side of the housing with SAE 90 gear oil.
- Remove plastic cap on air inlet and pour 2 oz. turbine oil into pump. Start pump slowly and with valve in suction position, pour 2 oz. turbine oil into air inlet.
- At this point oil should be visible in the dripper or oil lines. Adjust dripper flow to 1 drop every 2 seconds.

**Dripper will be shipped loose or taped to the bottom of the changeover valve handle.*

Testing flow rate after adjustment

1. Observe oil drip rate in oil view meter or oil line to ensure adequate lubrication.
2. Adjustments should be done gradually so as not to starve the vacuum pump of oil.

Recommended lubrication

We recommend that turbine grade oil be used in all our pumps. Turbine oil is more highly refined than motor oil and is much less likely to create carbon. Turbine oil is available from your local oil distributor. Below is a list of acceptable oils.

- Penzoil Penzabell 68 T.O.
- Shell Turbo 68
- Mobil D.T.E. Heavy – Medium
- Texaco Regal R.N.O. 68

Normal operation for air cooled pumps:

1. Check oil reservoir daily and fill as required.
2. When pump is in operation check oiler to insure flow of oil to pump.
3. Do not operate pump faster than recommended RPM.
4. To operate suction valve on top of pump, move handle in the appropriate direction for either vacuum or pressure; center it for neutral.
5. We recommend checking vane wear every twelve months. A new vane is nearly flush with the rotor. Measure the wear and if is over 1/4" we recommend replacing vanes. It's good to always keep a spare set of vanes on hand for emergencies.

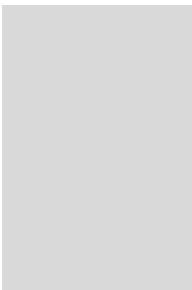

Maintenance

- With force feed type, the lubrication rate is adjustable at dripper and should be checked on a regular basis. Oil should be supplied to pump at a rate of 1 drop every 2 seconds.
- Average usage of oil is approximately 1-2 qts. per 40 hours, depending on operation.
- Oil should be changed every 2000 hours in gear per housing, if equipped.
- Front bearing should be greased approximately every 4 months. Use caution when greasing bearing not to over grease, as this can cause damage to seals.
- Normal vane life is approximately 2000 hours; however, this will vary greatly with temperature, material being pumped and proper maintenance.
- Occasionally liquid and dirt may enter the pump causing vanes to stick in the rotor slots along with excessive vane and housing wear. When this occurs you must clean the inside of the pump.

Cleaning the inside of the pump

- Remove air inlet hose or pressure relief valve.
- Run pump at an idle with the changeover valve in neutral.
- Pour 1 pint of diesel fuel into pump through the air inlet or fitting. Allow pump to run for 30 seconds then turn the change over valve to vacuum.
- Repeat two steps above several times, and then pour 2 oz. of oil into the pump and reassemble.

- Stop pump and turn slowly by hand while listening for vanes dropping. All vanes should move freely in the rotor slot.
- It is good practice to clean your pump on a regular basis as this will normally increase the life of your pump greatly.
- Vane wear should be checked every 12 months. A new vane will be flush with the outside diameter of the rotor.
- When vane wear exceeds 1/4" the vanes should be replaced. It is a good idea to have an extra set of vanes, seals and gaskets on hand at all times.

Determining the rotation of the pump

As one faces the drive end of the pump:

- For 1000 RPM pumps with the oiler on the right side, the pump shaft turns clockwise.
- For gear driven pumps (540 RPM) with the oiler on the right side, the pump shaft turns counterclockwise.
- If you must change the rotation of your pump contact the factory for instructions before attempting it.

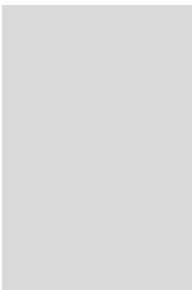

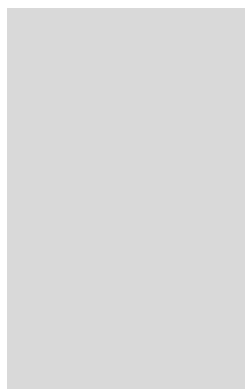

Troubleshooting

MEC 1000/P
MEC 1600/P



Pump overheats

- No oil in pump
- Oil adjustment set too lean
- Rpm too fast
- Prolonged operation

Too much oil use

- Oil adjustment set too rich
- Oil seals defective
- Cracked pump body

Pump doesn't turn

- Broken vane
- Frozen
- Pump endplate bolts too tight
- Faulty PTO or drive set up

No vacuum or pressure in tank

- Suction valve in neutral
- Defective seal or vanes
- Pump not driven fast enough
- Check valve or suction line clogged
- Leak in tank or fittings

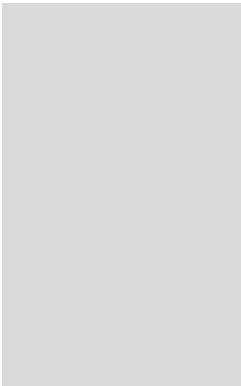

Pump Rebuilding

MEC 1000/P

MEC 1600/P

**Please read
these instructions
completely before
attempting repair.**



Vane checking

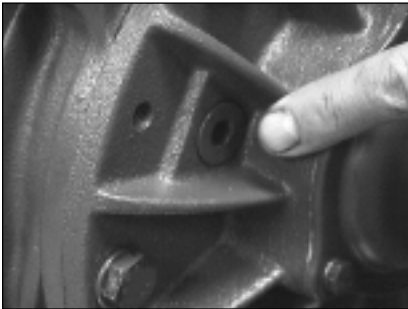

1. MEC pumps are equipped with a vane checking port.
2. Remove the Allen head plug in an endplate.
3. Measure the wear.
4. If the wear is more than 1/4" the vanes should be replaced.

Vane replacement



1. Clean off the exterior of the pump.
2. Remove the oil supply line at the oil pump and drain the oil tank.

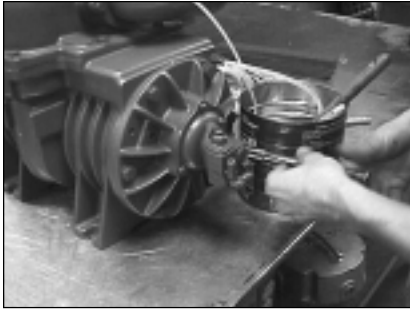

3. Remove the 3 6x20mm screws attaching the oil pump assembly to the vacuum pump.



4. Remove the oil pump drive key from the end of the rotor.

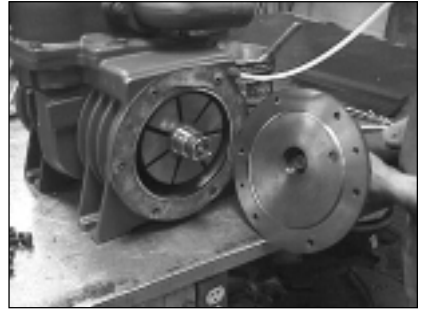

5. Remove the six bolts that attach the endplate to the pump.

Secure two 10x50mm bolts to screw into pull holes.

Screw the bolts into the pull holes evenly and pull off the endplate.

If you cannot locate 10x50mm bolts, you can use the endplate bolts and shim behind the endplate as the endplate comes off.

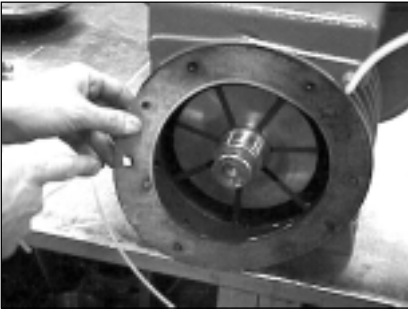

6. Note the number of gaskets on the endplate. You must use the same number of gaskets during reassembly.



7. Inspect vanes, bearings and seals and replace as necessary.

A new vane is flush with the outside diameter of the rotor.

If they are worn more than 1/4" they should be replaced.

We recommend replacing vanes in sets.

If the ends of the vanes are chipped or delaminated they should be replaced.

The seals should be soft and pliable.

The bearing should turn smoothly.

8. Clean the rotor, rotor slots and housing and inspect for wear or damage.



9. Coat the housing and vanes with oil and install the vanes in the rotor. The vanes should slide freely in the vane slot.



10. Locate the replacement seals and install them in the endplate with the seals positioned back to back.

11. Lubricate and install the bearing in the endplate.



12. Locate the proper number of gaskets and install them on the endplate.

Do not use any gasket sealer.

Locate the two 10x50mm bolts used for pulling the endplate and insert them in bolt holes on either side of the endplate to capture the gasket.



13. Lubricate seal sleeve and install the endplate on the end of the rotor and carefully drive the endplate on the rotor.

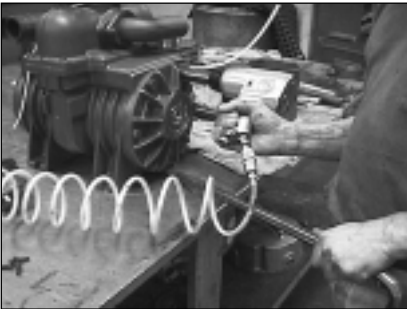

14. When the endplate is close enough to the housing install the endplate bolts lift the endplate-rotor assembly to allow proper alignment of the bolts and bolt holes and start the bolts into the housing.

Just prior to making contact with the housing, lift the endplate -rotor assembly again to insure proper clearance between the rotor and the housing.

Tighten endplate bolts to 35-40 ft lb of torque.



15. Seat the bearing with a bearing driver or punch.



16. At this point you should be able to turn the pump by hand.



17. Reinstall the oil pump drive key and oil pump mount assembly to the pump.

Be sure to line up the oil pump drive key and the oil pump shaft prior to tightening the assembly to the pump.

18. Connect the oil lines to the oil pump .

The pump is now ready to run.

19. Start the pump at a slow RPM and allow to run for a few minutes until oil can be seen in the lines.

The pump is now ready to go to work.

Complete rebuild

1. Follow steps 1-7 in the vane replacement instructions.

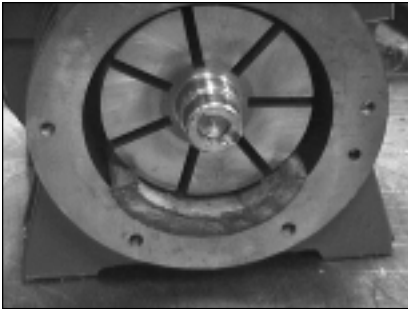

2. Place a cushion under the rotor to prevent damage when the front endplate is unbolted.



3. Remove the six bolts attaching the endplate to the housing.

Support the rotor shaft prior to loosening the last bolt.

Slide the rotor out



4. Remove the front endplate, front bearing and bearing cover from the rotor with a puller or hydraulic press.

Put an identifying mark on the endplate so as to not confuse it with the rear.



5. Count the number of gaskets.

6. Clean the rotor, rotor slots and housing and inspect for wear or damage.

If the housing needs to be bored or honed, remove only as much material as is necessary to give a smooth clean bore.

The maximum over bore we recommend is .060 inch. (A new housing has a bore of 6.300 inches.)

If you bore or hone the housing, remove the four way valve assembly and internal check valve ball prior to machining.



7. Inspect vanes, bearings and seals and replace as necessary.

A new vane is flush with the outside diameter of the rotor.

If they are worn more than 1/4" they should be replaced.

We recommend replacing vanes in sets.

If the ends of the vanes are chipped or delaminated they should be replaced.

The seals should be soft and pliable.

The bearing should turn smoothly.



8. Locate the replacement seals and install them in the endplates with the seals positioned back to back.

Replace the seal in the bearing cover with the lip facing outward.



9. Lubricate and install the bearings in the endplates.



10. Locate two pieces of threaded rod 3/8-18 thd. to use as guides and screw them into the two top holes in the housing.

Locate proper number of gaskets and slide on the threaded rods.

Do not use any gasket sealer.

11. Lubricate the housing bore.



12. Lubricate seal sleeve and drive the proper endplate on the input end of the rotor.

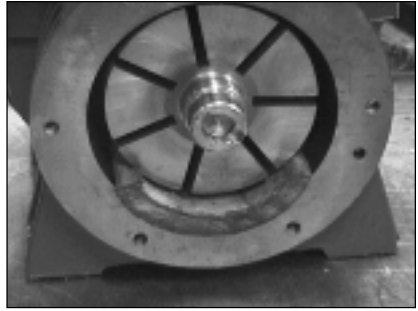

13. Slide rotor-endplate assembly into the pump housing.

Slide the cushion material used during disassembly under the rotor on the opposite end to gain leverage during assembly of endplate to housing.

14. Lift the rotor-endplate assembly and slide over the 3/8 inch threaded guides and install the endplate bolts.

Tighten the bolts sufficiently to make contact between the endplate and the housing.



15. Coat vanes with oil and install the vanes in the rotor. The vanes should slide freely in the vane slots.

16. Locate the proper number of gaskets and install them on the rear endplate.

Do not use any gasket sealer.

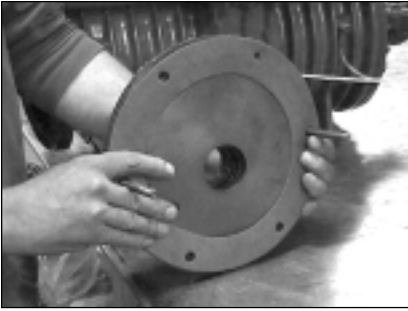

Locate the two 10x50mm bolts used for pulling the endplate and insert them in bolt holes on either side of the endplate to capture the gaskets.

17. Lubricate seal sleeve and install the endplate on the end of the rotor and carefully drive the endplate on the rotor.

18. When the endplate is close enough to the housing install the endplate bolts lift the endplate-rotor assembly to allow proper alignment of the bolts and bolt holes and start the bolts into the housing.

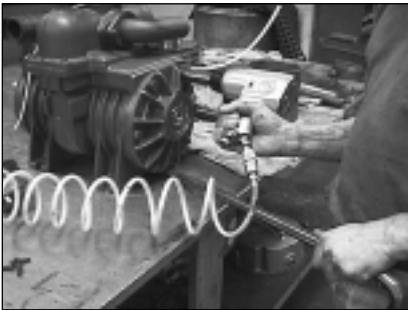

Just prior to making contact with the housing, lift the endplate-rotor assembly allow the endplate to enter the housing.

Tighten endplate bolts to the point where the endplate just touches the housing.

19. With a prybar and a block of wood, lift the endplate to make certain the seal gap is properly set and tighten the endplate bolts to 35-40 ft lb of torque.

Tighten both endplates in this manner.

20. Seat the bearings on both endplates with a bearing driver or punch.

21. At this point you should be able to turn the pump by hand.



22. Install the seal in the front bearing cover.

Lubricate the seal and seal surface on the rotor and install the front bearing cover.



Reinstall the oil pump drive key, oil pump mount assembly, and gaskets to the pump.

Be sure to line up the oil pump drive key and the oil pump shaft prior to tightening the assembly to the pump.

23. Connect the oil lines to the oil pump.

The pump is now ready to run.

24. Start the pump at a slow RPM and allow to run for a few minutes until oil can be seen in the lines or dripper.

Limited Warranty

Parts List – MEC /P Series Pumps

MEC 1000/P

MEC 1600/P



See Parts Diagram on the next page.

Part #	Description	Part #	Description
BM1	Housing – 1000	M36	Exhaust Pipe
BME1	Housing – 1600	BM37	Gasket
BM3	Endplate	BM38	4-way Valve Housing
BM4	Gasket	BM39	Gasket
BM5/P	Rotor – 1000/P	BM40	Seal
BME5/P	Rotor – 1600/P	BM41	Non-return Ball
BM7	Vane – 1000	BM42	Gasket
BME7	Vane – 1600	BM44	Dripper
BM8	Fitting	BM45	Spring
BM9	Handle Set Screw	BM46	Hose
BM10	Dipstick	BM47	4-way Valve Plug
BM11	Bolt	BM49	Bearing
BM13	Gasket	BM50	Front Bearing Cover
BM14	Rear Bearing Cover	BM51	Washer
BM16	Bolt	BM52	Key
BM17	Washer		
BM18	Seal		
BM19	Bolt		
BM20	Washer		
BM22	Handle		
BM31	Air Inlet – 45mm		

Detail
Gear-Type Lubrication System
MEC 1000/P • MEC 1600/P

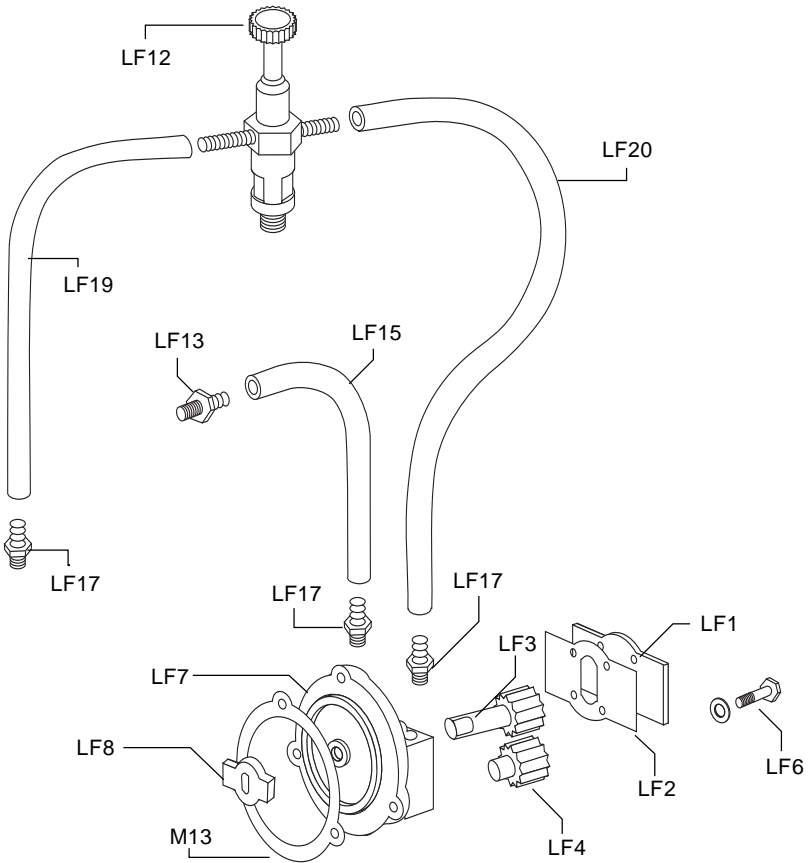

Oil Tank Cover Plate

MEC 1000/P and MEC 1600/P

Part # Description

BM8	Fitting
BM10	Dipstick
BM19	Bolt
BM20	Washer
BM39	Gasket
BM44	Dripper
BM46	Hose
BM73	Cover Plate

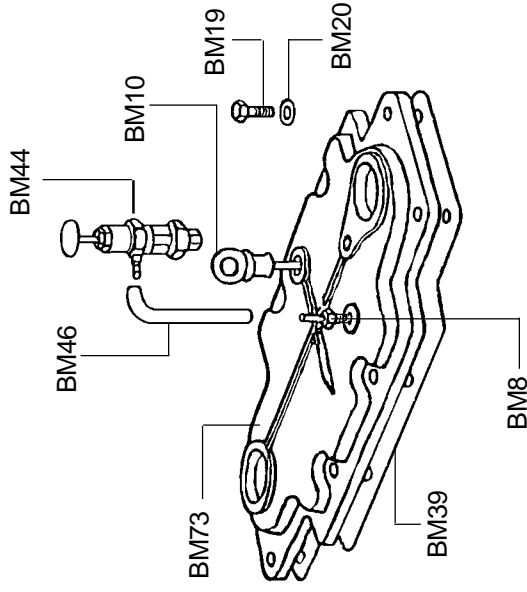

MEC 1000/540 - 1600/540

MEC 1000/540 – MEC 1600/540

Parts Diagram

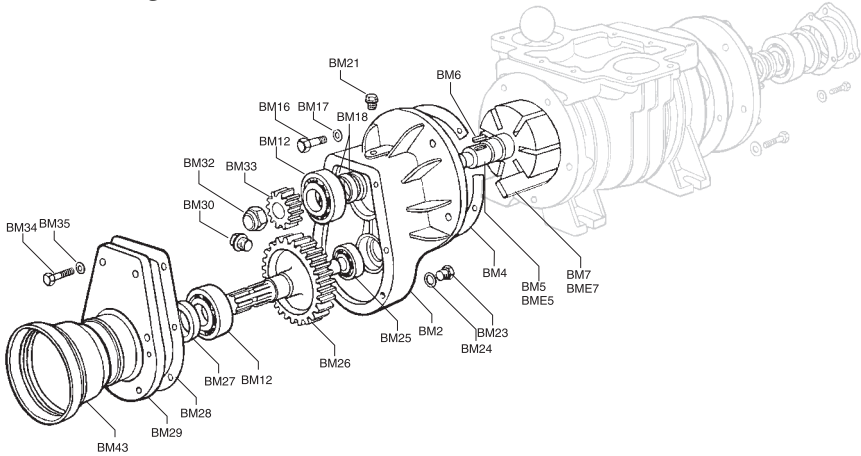

Part #	Description	Part #	Description
BM2	Gear Casing	BM24	Washer
BM4	Gasket	BM25	Bearing
BM5	Rotor - 1000/540	BM26	Gear
BME5	Rotor - 1600/540	BM27	Seal
BM6	Key	BM28	Gasket
BM7	Vane - 1000	BM29	Gearbox Front Cover
BME7	Vane - 1600	BM30	Plug
BM12	Bearing	BM32	Locknut
BM16	Bolt (m10x30)	BM33	Gear
BM17	Washer (10)	BM34	Bolt (m8x25)
BM18	Seal (48-62-8)	BM35	Washer (8)
BM21	Oil Fill Cap	BM43	PTO Guard
BM23	Oil Drain Nut		

Index

A

Air Flow 11

B

Bearing

11, 18, 25, 29, 30, 34

Bearing cover 29, 31

Bearing driver 34

Bore 30

C

Check Valve, Anti-Spin 11

Check valve ball 30

Cleaning 18

Clockwise 19

Components 13

Counterclockwise 19

Coupling 15

Cushion 29

Cushion material 32

D

Diesel fuel 18

Dripper 16, 18

Drive key 24, 28

E

Endplate 21, 24, 29, 32, 33

F

Four way valve 30

G

Gasket sealer 26, 31, 33

Gaskets 19, 25, 30, 31, 33

Greasing 18

Guides 31

H

Hose 15

Housing 25, 29

Housing bore 31

Housing, boring or honing 30

Hydraulic press 29

I

Identifying mark 29

Installation 15

Instructions, rebuilding 23

L

Lubricate 26, 31

Lubrication 11, 16

Lubrication rate 18

M

Maintenance 8

Manifold 11

Manufacturer's warranties 8

Muffler 15

O

Oil 18

Oil adjustment 21

Oil lines 28, 34

Oil pump 34

Oil pump shaft 28

Oil reservoir 17

Oil tank capacity 11

Oil, turbine grade 17

Oil, using too much 21

Oiler 17, 19

Operation, normal 16

Overheating 21

Owner's Record 1

P

Parts Diagram Foldout 35

Parts List 35

Performance 12

Portal F-801 13

Porting size 11

Pressure, continuous 11

Pressure, intermittent 11

Pressure relief valve 18

Prybar 33

PTO 21

Pull holes 24

Puller 29

Pump body 13

Pump doesn't turn 21

Punch 34

R

Rebuild, complete 29

Rebuilding 23

Recommended Lubrication 17

Registration card 7

Repair 23

Return goods authorization 9

Rotation 11, 15

Rotation, changing 19

Rotor 13, 25, 29, 30, 32

Rotor shaft 29

Rotor slots 25

Rotor-endplate assembly 32

RPM 17, 21

RPM Range 11

S

Seal sleeve 27, 31

Seals 19, 21, 25, 26, 30

Serial number 7

Serial number tag 9

Specifications 11

System requirements 13

T

Tank 22

Threaded rod 31

Torque 27, 33

Troubleshooting 21

Turbine oil 17

V

Vacuum, continuous 11

Vacuum, intermittent 11

Vacuum, none in tank 22

Valve, changeover 18

Valve, check 22

Valve, four way 11

Valve, pressure relief 18

Valve, suction 17

Vane 13, 19, 21
Vane breakage 8
Vane life 18
Vane replacement 23, 29
Vane wear 17
Vanes 25, 30, 32
Vanes, chipped or delaminated
25, 30

W

Warranty 7
Warranty procedure 9
Washers 15
Weight 11
Woods Sure Flex Couplers 15

