

Designed, Built, Proven & Supported in the **USA**.

Finally, an effective way to keep debris out of your pump! Designed specifically for Challenger series vacuum pumps & blowers in our Traverse City Michigan fabrication plant. This unit incorporates a true cyclonic motion to knock the grit & debris from the airflow. The waste product accumulates in the lower chamber where it is easily removed through a 2" drain or by lifting the cover for access.

GRIT RIDDER CYCLONE

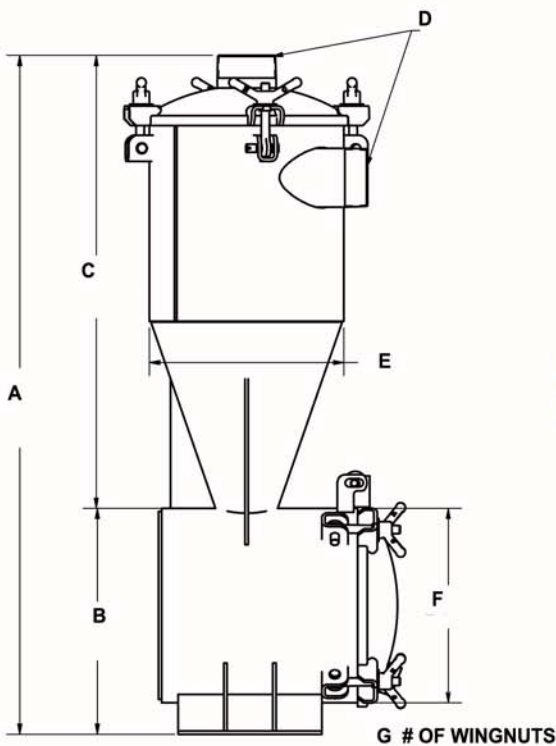

Separates
the grit from
the air for
cleaner airflow

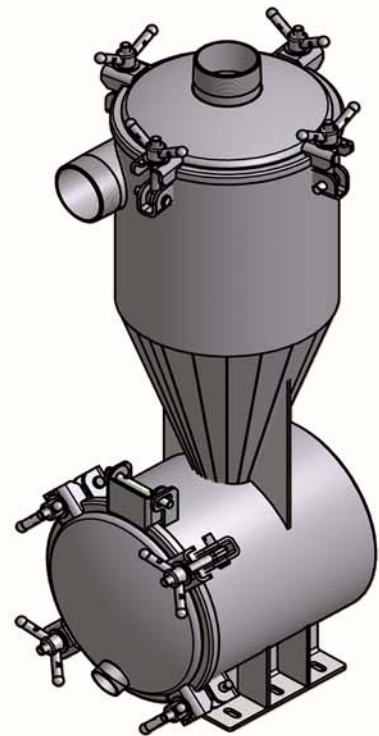

		Dimensions								
Model	PART #	A	B	C	D	E	F	G		
500 CFM	222-600-1	42 13/16	14 5/16	27 7/8	3"NPT	12 3/4	12 3/4	3		
1000 CFM	222-900-1	51 15/16	17 5/16	34 11/16	4"NPT	14 7/8	14 7/8	4		
1500 CFM	222-2400-1	62 9/16	20 1/12	42 1/16	6"NPT	16 7/8	16 7/8	4		