

NVE

National Vacuum Equipment

New Defender 500 by Challenger

Ballast Port Cooled

Built and Supported in the **USA**

310 CFM at 1200 rpm

- Commercial Duty
- Ballast Port Cooled
- Continuous Duty at 18" H.g.
- Automatic Lubrication
- Built-in Oil Reservoir

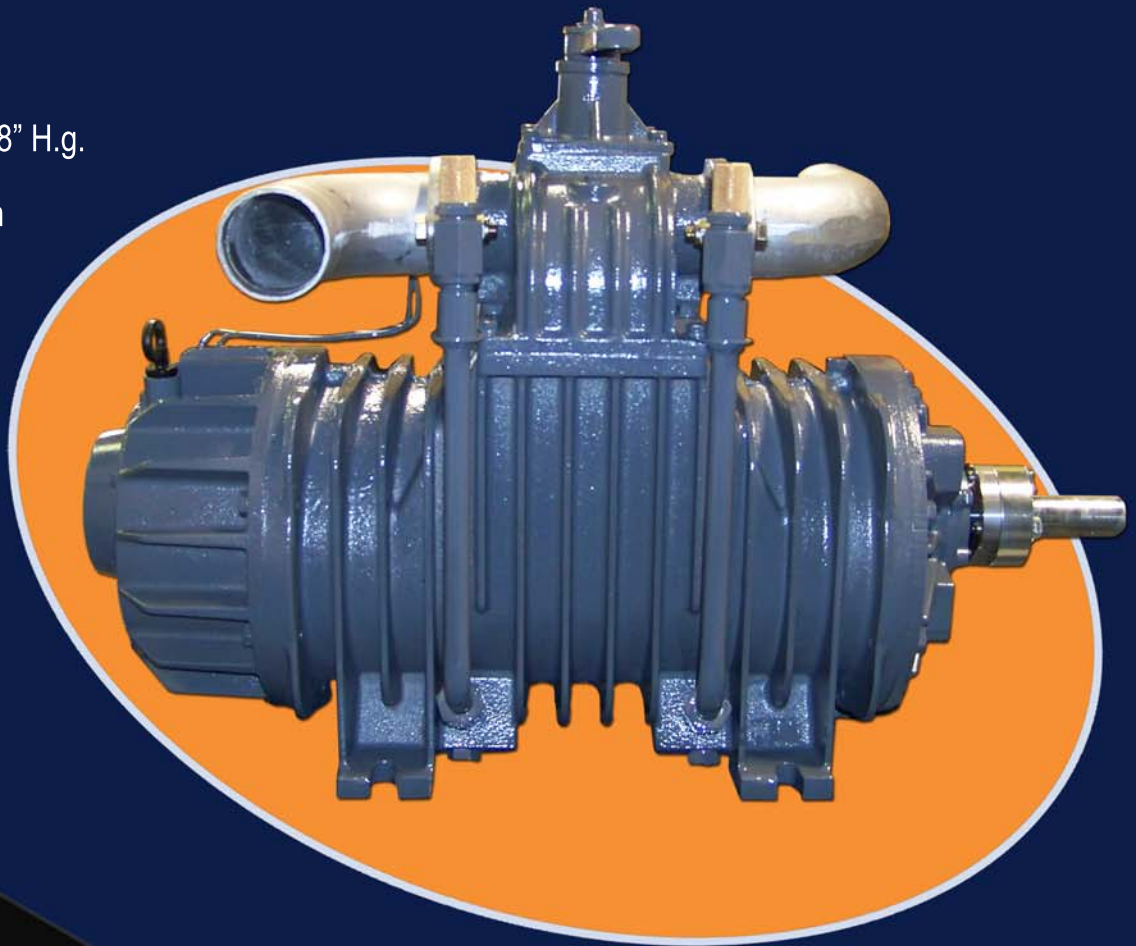

Defender 500 Max Pak

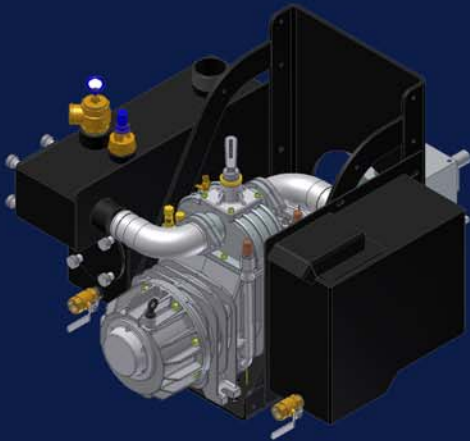

Packaging Made Perfect

National Vacuum Equipment

2670 Aero Park Drive

Traverse City, MI 49686 USA

800-253-5500 | sales@natvac.com

www.natvac.com

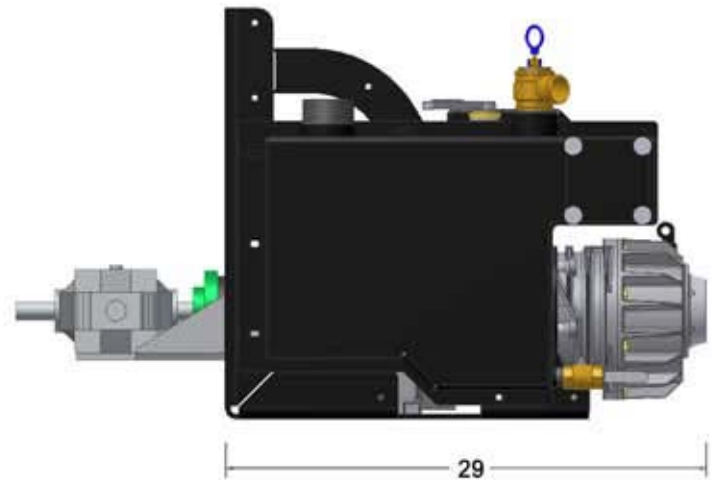
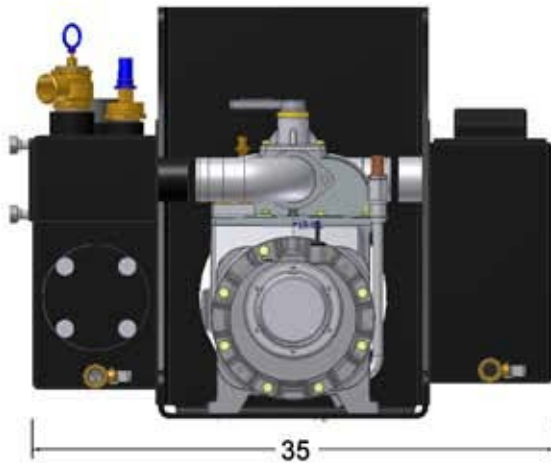
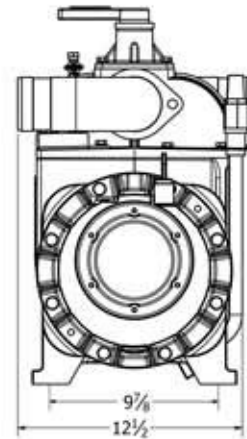
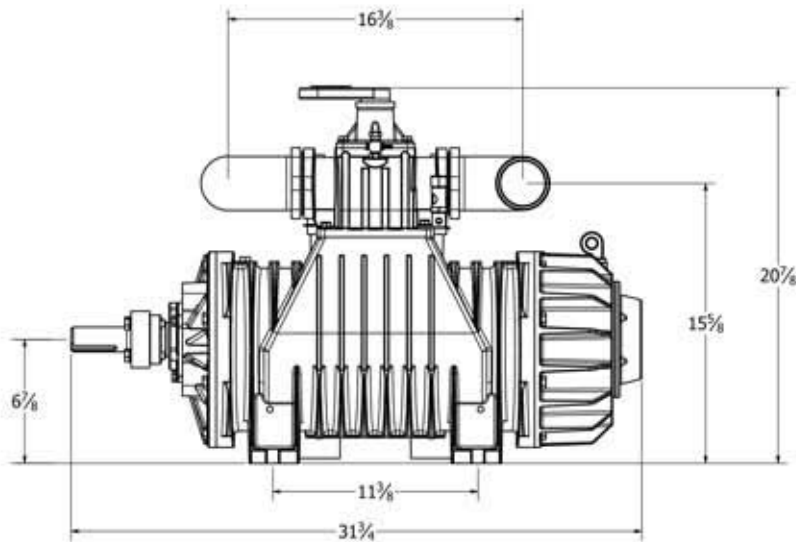

DEFENDER 500 FEATURES

- 310 cfm at 1200 rpm
- RPM Range 1000 - 1200
- Max Intermittent Pressure 21 PSI
- 18 Horsepower
- 1 3/8" Shaft
- Net Weight 397 lbs
- Ballast Port Cooled
- Automatic Lubrication
- 4 way Change Over Valve
- 3" Swivel Elbows
- Heat Resistant Kevlar Vanes
- Built In Oil Reservoir
- Built and supported in the USA