

NVE 200/MAL Challenger Pump

Owner's Record

Date of Purchase: _____

Purchased from: _____

Serial Number: _____



National Vacuum Equipment, Inc.

© 2004 National Vacuum Equipment, Inc.

No part of this manual may be reproduced without the written permission of National Vacuum Equipment, Inc.

Contents

Introduction

About National Vacuum Equipment, Inc.	5
---	---

Limited Warranty

Warranty	7
Warranty Procedures	9

NVE 200/MAL Pump

Application	11
Pump Specifications	11
System requirements	12
Drive system	13
Direction of rotation	13
Factory Settings	13
Adjusting Factory Settings	14

Operating Instructions

Normal Operation	17
Lubrication System	18
Recommended Lubricant	18
Maintenance	18
Cold Weather Operation	20

Troubleshooting

Pump overheats	21
Pump uses too much oil	21
Pump doesn't turn	21
No vacuum	22
System Troubleshooting	22
Making a vacuum tester	23

Table of Contents continues on next page.

Pump Rebuilding

Vane Replacement	25
Complete Rebuild	32

Parts List

Parts List	39
Parts Diagram	41
Automatic Oil Pump Parts List and Diagram ...	42

Index

Introduction



General Information

About National Vacuum Equipment, Inc.



Congratulations! You now own a quality vacuum/pressure pump proudly manufactured in the U.S.A. by National Vacuum Equipment, Inc. You have not only acquired a superior piece of equipment from a qualified dealer, you have hired a team of vacuum experts. We stand ready to work with your dealer to answer your questions and provide you with the information necessary to keep your equipment in peak working condition.

Thank you for using National Vacuum Equipment.

OUR MISSION:

We are dedicated to the manufacture and wholesale distribution of quality vacuum system products at a reasonable price, on a timely basis. We are a “one-stop shop” for manufacturers and distributors of vacuum equipment.

OUR HISTORY:

National Vacuum Equipment, Inc. was founded in 1980 by Bruce Luoma. The Company started as a retailer of vacuum pumps. Soon after it started, the Company secured the rights to exclusive distribution of the Battioni vacuum pumps in North America. This helped the Company to evolve into its current status as a wholesale supplier.

To reach the goal of becoming a full service supplier of vacuum system components, the Company began fabricating its own line of componentry, purchased and developed its own line of vacuum pumps, and began purchasing for resale various valves and accessories.

Today, NVE has full service machine and fabrication shops complete with CNC-controlled production equipment designed for close tolerance work. The company has a highly trained staff all of whom are dedicated to quality.

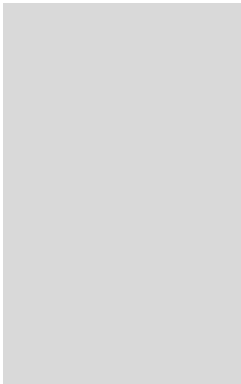

Limited Warranty

NVE 200/MAL



National Vacuum Equipment, Inc.

guarantees that the product it provides is free of manufacturer's defects, including materials and workmanship. Properly installed and maintained product is warranted for a period of one (1) year subject to the following conditions:

1. A properly completed warranty registration card must be received by us within 30 days of sale to end user for pump sales to be considered warrantable. All pumps received for warranty consideration must retain the original NVE serial number tag.
2. The one (1) year period shall begin the day the product is shipped from our warehouse, unless we are provided with an authentic copy of the original resale invoice, in which case the one (1) year period shall begin at such invoice date.
3. The covered product must be used in an application for which it was intended. We do not recommend our product for particular uses or applications.

4. Vane breakage, or damage caused by vane breakage, is not warrantable.
5. Damage caused by improper use or lack of proper maintenance is not warrantable.
6. Manufacturer's liability under this or any other warranty, whether express or implied, is limited to repair of or, at the manufacturers option, replacement of parts which are shown to have been defective when shipped.
7. Manufacturer's liability shall not be enforceable for any product until National Vacuum Equipment, Inc. has been paid in full for such product.
8. Except to the extent expressly stated herein, manufacturer's liability for incidental and consequential damage is hereby excluded to the full extent permitted by law.
9. Manufacturer's liability as stated herein cannot be altered except in writing signed by an officer of National Vacuum Equipment, Inc.
10. Certain products provided by National Vacuum Equipment, Inc. are covered by their respective manufacturer's warranties (e.g., engines used in the NVE engine drive packages). These products are not covered by the National Vacuum Equipment, Inc. Manufacturer's Warranty.

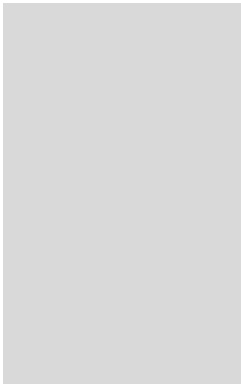

Should a potential warranty situation arise, the following procedures must be followed:

- Contact your dealer immediately upon the occurrence of the event and within the warranty period.
- Customer must receive a return goods authorization (RGA) before returning product.
- All serial-numbered products must retain the NVE serial number tag to be qualified for warranty.
- Product must be returned to NVE intact for inspection before warranty will be honored.
- Product must be returned to NVE freight prepaid in the most economical way.
- Credit will be issued for material found to be defective upon our inspection, based upon prices at the time of purchase.

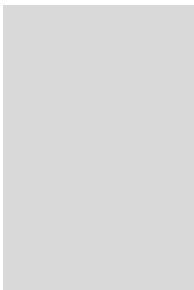

NVE 200/MAL Pump

Model-Specific Information



NVE 200 Challenger Specifications

Model Number	184
RPM Range	1000 - 1500
Maximum Air Flow-CFM	255
Maximum Continuous Vacuum	20
Maximum Intermittent Vacuum	27
Maximum Continuous Pressure	10
Maximum Intermittent Pressure	20
Pump Drive Rotation	CW/CCW
Porting Size	2"
End Thrust Protection	Standard
Anti-Spin Check Valve	Optional
Automatic Lubrication System	Optional
Hydraulic Motor Mount	Optional
Net Weight	198 lbs

Performance

NVE 200/MAL PERFORMANCE

RPM		Pressure (P.S.I.)				Free Flow	Vacuum (In. Hg.)					
		20	15	10	5	0	5	10	15	20	25	27
1500	H.P.	20.5	22.4	18.3	14.5	9.9	10.1	11.4	13.2	15.0	17.6	18.0
	CFM	214	225	236	247	255	246	241	235	221	201	174
1250	H.P.	21.5	18.0	14.4	10.9	7.2	8.0	9.1	10.4	12.0	14.5	14.5
	CFM	174	163	152	140	127	121	116	111	100	103	142
1000	H.P.	16.1	13.7	11.3	7.3	4.4	5.3	6.2	7.6	9.3	12.2	14.2
	CFM	136	143	149	156	161	157	153	148	140	127	110

**1250 RPM Recommended Setup
for optimum performance**

**1500 RPM Intermittent
Operation Only**

System requirements

High quality components

- The NVE 200/MAL is a high performance vacuum pump and requires compatible, high quality components.

Shutoffs

- We recommend the use of our Part # F-803-A, 8" portal shutoff, and our Part # F-901-2A, 4 gallon scrubber/secondary shutoff.

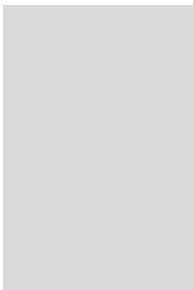

Hose

- Use 2" or larger hose to plumb your system. We recommend you use a hose that can withstand high temperatures such as hot tar-asphalt hose.

Pressure relief and vacuum relief valves

- A pressure relief valve and vacuum relief valve should also be incorporated in the system.
- The pressure relief valve should be set for a maximum of 25 p.s.i.
- The vacuum relief valve should be set for 20" hg.

Drive system

- The pump should be mounted on a level, horizontal surface, secured with grade 5 or better fasteners.
- The drive system should be sized to supply the required horsepower to the pump plus a reserve to insure long life.
- Make certain that all shafts, pulleys or turning parts are properly guarded.
- Check the ratio of the drive system prior to installation to verify that the pump will be turning at the proper speed.

Direction of rotation

- The direction of rotation and rpm are marked on the front of the pump.
- The direction of rotation required by your drive system should be determined prior to ordering the pump.
- If during assembly of your unit you find you need the opposite rotation, call the factory for instructions.

Factory Settings

- The automatic oil pumps are set at the factory during pump testing and should require no further adjustment during pump installation.
- The pumps are adjusted to one drop every two seconds per outlet. This oil rate equals 2.7 fluid oz. per hour. The 200 is a (2) port oil system so it should use 5.4 oz. per hour

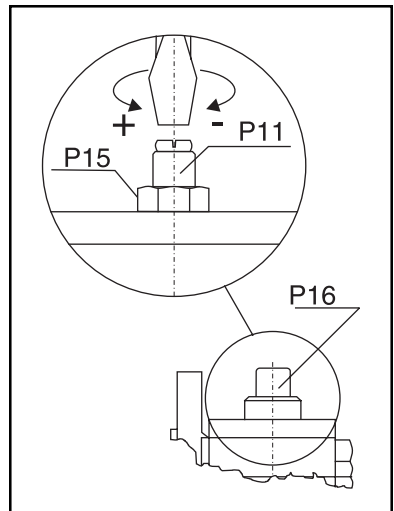

Adjusting Factory Settings

The automatic oil pump is a metered piston-type pump.

If you wish to adjust the pump, please follow these instructions:

Adjusting the oil rate

Oil flow is changed by adjusting the length of the stroke of the piston.

1. To adjust the oil rate, remove cap #P16. Under this cap you will find a jam nut #P15 and adjusting screw #P11.
2. To adjust oil rate loosen jam nut and turn adjusting screw clockwise to reduce oil flow or counterclockwise to increase oil flow.
3. When making adjustments do so one turn of the screw at a time and test before making further adjustments.
4. Be careful to not turn adjusting screw too far counterclockwise as you may disengage the gears and strip them out.

Testing flow rate after adjustment

1. Observe oil drip rate in oil view meter to ensure adequate lubrication.
2. Adjustments should be done gradually so as not to starve the vacuum pump of oil.

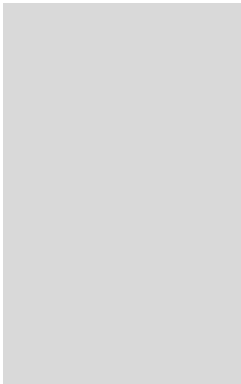

Operating Instructions

NVE 200/MAL



Normal Operation

Oil reservoir

- Check oil reservoir daily and fill as required.

Drippers

- When pump is operating, check the dripper to insure proper oil flow to the pump.

Recommended rpm

- Do not operate the pump faster than the recommended rpm.

Suction valve

- To operate the suction valve, move the handle in the appropriate direction for either vacuum or pressure; center is neutral.

Vacuum levels

- Do not operate your pump for extended periods of time at vacuum levels exceeding 24" hg.

Guards

- Make certain all guards are in place prior to running your pump. Think safety!

Lubrication System

Force feed system

- The NVE 200/MAL is supplied with a force feed type lubrication system which incorporates a piston type pump and two point oiling.

The drip rate is preset at the factory.

- If any adjustments are required please see “Adjusting Factory Settings” on page 14.

Recommended Lubricant

- We recommend that turbine oil be used in our pumps. Turbine oil is much more resistant to breakdown due to heat than normal motor oil, thereby avoiding the problems associated with motor oil such as lacquering and excessive wear.
- Acceptable oils:
Penzoil Penzabell 68 T.O.
Shell Turbo 68
Mobil D.T.E. Heavy – Medium
Texaco Regal R.N.O. 68

Maintenance

Washing

- Periodically wash the mud and dirt off your pump. The NVE 184/DS is an air cooled pump. It must be clean to allow heat to radiate from it.

Flushing

We recommend periodic flushing of your pump. To do this:

1. Remove the 3/8" pipe plug from the intake port of your pump. Install the hose barb and hose supplied.
2. Put the end of the hose in a one pint container of diesel fuel. Start your pump and run as slow as possible.
3. With the suction valve in the vacuum position, monitor the diesel flow to your pump.
4. When the diesel fuel is gone switch the suction valve to neutral and run the pump for 2 minutes.
5. Speed the pump up to normal rpm, switch the suction valve to vacuum.
6. Remove the hose barb and replace the pipe plug.
7. Properly dispose of used oil and flushing fluid.

Checking vane wear

- We recommend checking vane wear at least every 12 months.
- A new vane is flush with the outside diameter of the rotor.

- Vanes that are worn more than 1/4" should be replaced.
- Vanes should be replaced in sets and it is always a good idea to have an extra set of vanes on hand for emergencies.

Cold Weather Operation

Confirm pump is not frozen.

- Prior to engaging the pump, turn by hand to confirm it is not frozen.

If pump is frozen, thaw it.

- If the pump is frozen, thaw it out by heating the bottom of the pump with a torch or move the truck into a heated building.

Avoid freezing problems.

- You can avoid freezing problems by putting a small amount of diesel fuel into the pump at the end of the day.

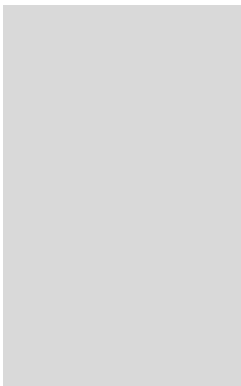

Troubleshooting

NVE 200\MAL Pump



Pump overheats

- No oil in pump
- Oil adjustment set too lean
- Rpm too fast
- Prolonged operation at excessive vacuum or pressure levels
- Pump dirty

Pump uses too much oil

- Oil pump set too rich; see operating instructions

Pump doesn't turn

- Broken vane or bearing
- Frozen
- Problem in the drive train

No vacuum

- Suction valve in neutral
- Worn seals or vanes
- Pump not turning fast enough
- Check valve or suction valve clogged
- Leak in tank or fittings
- Collapsed hose between pump & shutoffs

System Troubleshooting—Locating the source of the trouble

If you notice a decrease in pumping performance, start troubleshooting at the pump.

1. Remove the suction and discharge hoses at the pump.
2. Start the pump and run it in vacuum only at its normal rpm.
3. Check the vacuum level at the pump inlet. The NVE 200/MAL in new condition will develop 27-27.5" hg.
4. If the pump checks out OK, check the vacuum level at the secondary, then the primary shutoff. Keep working your way back until you find the problem.

Making a vacuum tester

1. Procure a flange to mount on your four-way valve, a short 2" pipe nipple, a 2" pipe cap and a vacuum gage.
2. Drill and tap a 1/4" N.P.T. thread in the pipe cap.
3. Assemble the flange, nipple, pipe cap and vacuum gage.
4. Remove a flange from the four-way valve on your pump.
5. Start the pump and confirm the location you have chosen to test from is at vacuum.
6. Using the existing O-ring, fasten the testing flange to your pump.
7. Start your pump and read the vacuum level on the gauge.

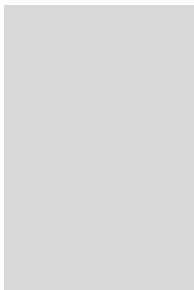

Pump Rebuilding

NVE 200/MAL Pump

Please read these instructions completely before attempting repair.

There are two types of pump repair—vane replacement and total rebuilding.

Vane Replacement



1. Clean off the exterior of the pump, drain and remove oil intake line from oil pump on the rear of the 200.



2. On the oil tank end, remove the oil lines and set them in a safe place. Make sure not to lose the small flares on the end of each line.



3. Remove the four cap screws that attach the oil pump mount to the vacuum pump and remove oil pump and pump mount assembly.



5. Remove the oil pump drive key from the end of the rotor.



6. Remove the four bolts that attach the endplate to the pump. Secure two 3/8-18 x 2 1/2 inch bolts to screw into pull holes. Screw the bolts into the pull holes evenly . . .



. . . and pull off the endplate.



8. Inspect vanes, bearings and seals and replace as necessary.

A new vane is flush with the outside diameter of the rotor.

If they are worn more than 1/4" they should be replaced.

We recommend replacing vanes in sets.

If the ends of the vanes are chipped or delaminated they should be replaced.

The seals should be soft and pliable.

The bearing should turn smoothly.



9. Coat the vanes with oil and install the vanes in the rotor. Ensure that the vanes are properly installed, the angle of the vane should match the outside of the rotor and not extend past the O.D. of the rotor.



10. Place the long guide pins into the dowel holes leaving about an 1 1/2" of the pin showing. To guide on the end plate.



11. Lubricate seal sleeve



12. Install the drive key into the rotor.



13. Place the endplate onto the guide pins and over the rotor shaft. When the endplate is close enough to the housing install the endplate bolts and start the bolts into the housing.



14. Tighten endplate bolts to 35–40 ft. lb of torque, and remove the guide pins.



15. align the drive key with the oil pump shaft and tighten the 4 oil pump assembly bolts



16. Reinstall the oil lines, fill the oil reservoir with oil. The pump is now ready to run. At this point the pump should turn freely by hand.

17. Start the pump at a slow R.P.M. and allow to run for a few minutes until the oil fills the oil lines and can get to the bearings.

The pump is now ready to go to work.

Complete Rebuild

1. Follow steps 1-9 in the vane replacement instructions.



2. Place a cushion under the rotor to prevent damage when the front endplate is unbolted.



3. From the drive end, remove the four screws that attach the bearing cover to the end plate.



4. Remove the bearing cover, and inspect the O-ring for damage.



5. Remove the four bolts holding the front endplate to the pump body.



6. Remove the front endplate from the rotor and inspect the o-ring for damage. Put an identifying mark on the endplate so as to not confuse it with the rear.



7. Clean the rotor, rotor slots and housing and inspect for wear or damage.

If the housing needs to be bored or honed, remove only as much material as is necessary to give a smooth clean bore.

The maximum overbore we recommend is .060 inch. A new housing has a bore of 6.635 inches.

If you bore or hone the housing, remove the four way valve assembly and internal check valve prior to machining.

If the housing is bored the top seal gap must be reset and the guide pins can not be used.





9. Locate the replacement seals and install them in the endplates with the seals positioned back to back.

Replace the seals in the bearing cover with the seals back to back.



10. Lubricate and install the bearings in the endplates.



11. Locate proper o-ring lubricate it and place it into the o-ring groove.

Do not use any gasket sealer.



12. Lubricate the housing bore.



13. Lubricate seal sleeve and insert the guide pins.



14. Drive the proper endplate onto the rotor and over the guide pins



15. Securely attach the endplate with the four original bolts and Tighten endplate bolts to 35–40 ft. lb of torque, remove the guide pins. Reassemble the oil line on the endplate.



16. Make sure the o-ring is lubricated and in place and bolt the bearing plate in place.



17. Place the long guide pins into the dowel holes leaving about an 1 1/2" of the pin showing. To guide on the end plate.



18. Lubricate seal sleeve



19. Install the drive key into the rotor.



20. Place the endplate onto the guide pins and over the rotor shaft. When the endplate is close enough to the housing install the endplate bolts and start the bolts into the housing.



21. Tighten endplate bolts to 35–40 ft. lb of torque, and remove the guide pins.



22. align the drive key with the oil pump shaft and tighten the 4 oil pump assembly bolts



23. Reinstall the oil lines, fill the oil reservoir with oil. The pump is now ready to run. At this point the pump should turn freely by hand.

24. Start the pump at a slow R.P.M. and allow to run for a few minutes until the oil fills the oil lines and can get to the bearings.

The pump is now ready to go to work.

NVE 200/MAL

Parts Diagram

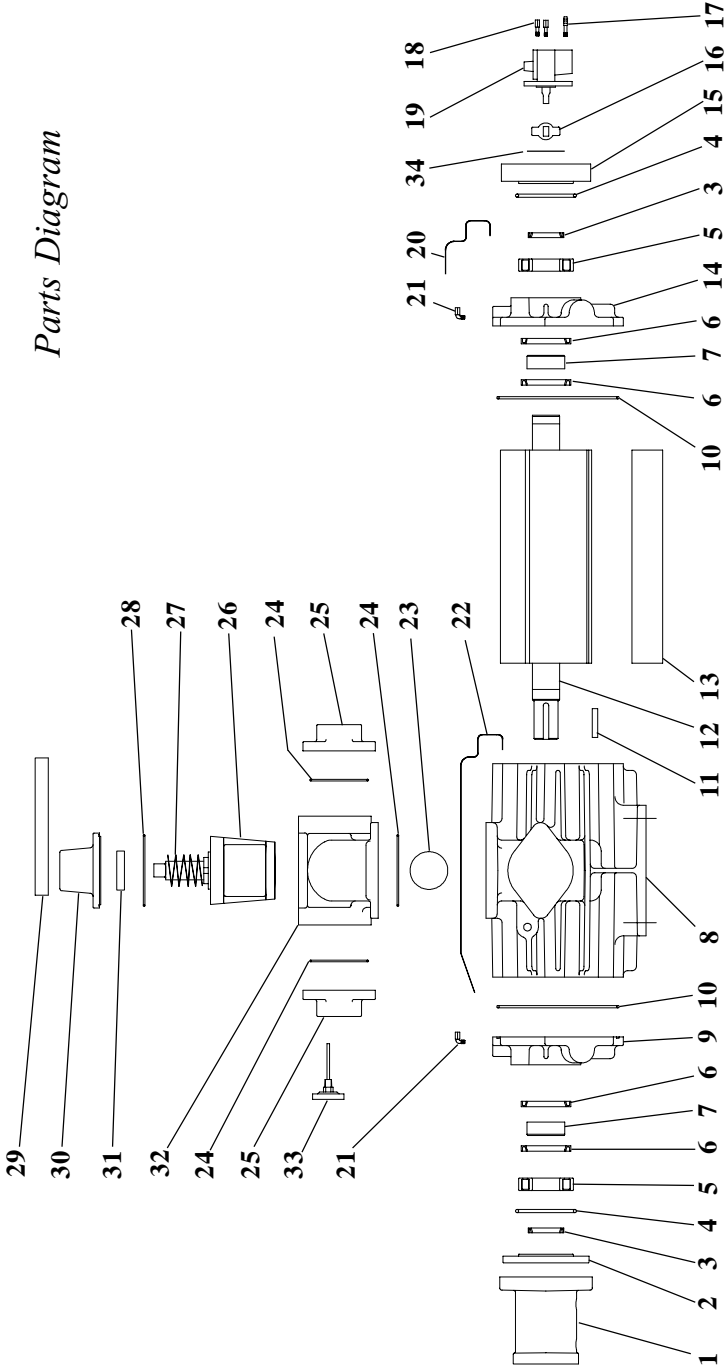

Key Part # Description

1	200-2H	Hydraulic Mount 200	18	LP52	Fitting M5x4
2	200-54	Bearing Cover 200	19	LW32S	Oil Pump 2 Port CCW
3	400-53V	Seal 40x52x7 Viton		LW32D	Oil Pump 2 Port CW
4	R01-152V	O-Ring, 2-152 Viton 75 Duro	20	200-LP90	10" Oil Line
5	200-48	Bearing, NJ208 C3	21	360-LP51	Oil fitting 90 deg.
6	400-18V	Seal 55x72x8 Viton	22	200-LP91	24" Oil Line
7	200-9	Seal Sleeve, 200	23	AP-312/B	Non-Return Ball 55mm
8	200-1	Housing, NVE 200 Challenger	24	180-39	Gasket, Flange
9	200-3S	Endplate, 200 LH Turning	25	180-38	Flange, 184 Intake & Exhaust
10	R01-166V	O-Ring, 2-166 Viton 75 Duro	26	AP-312/P	4-Way Valve Plug, 2"
11	350-6	Key 5/16" x 2"	27	AP-312/SP	Spring, 2" 4-Way Valve
12	200-5CW	Rotor, NVE 200 CW	28	AP-312/TG	4-Way Valve Tower Gasket, 2"
13	200-7	Vane, NVE 200	29	AP-312/RH	4-Way Valve Handle, 2"
14	200-3D	Endplate, 200 RH Turning	30	AP-312/T	4-Way Valve Tower, 2"
15	200-2AL	Oil Pump Mount, 200	31	AP-312/S	Seal, 2" 4-Way Valve
16	LF8	Drive Tab	32	AP-312/H	Housing, 200 4-Way Valve
17	LF13	Fitting, Housing Oil Reservoir	33	A-20025D009G2	Thermometer 50 to 400 deg. F.
			34	R31	Gasket, Oil Pump Mount

NVE 200 Challenger Automatic Lubrication System

Parts Diagram and Parts List

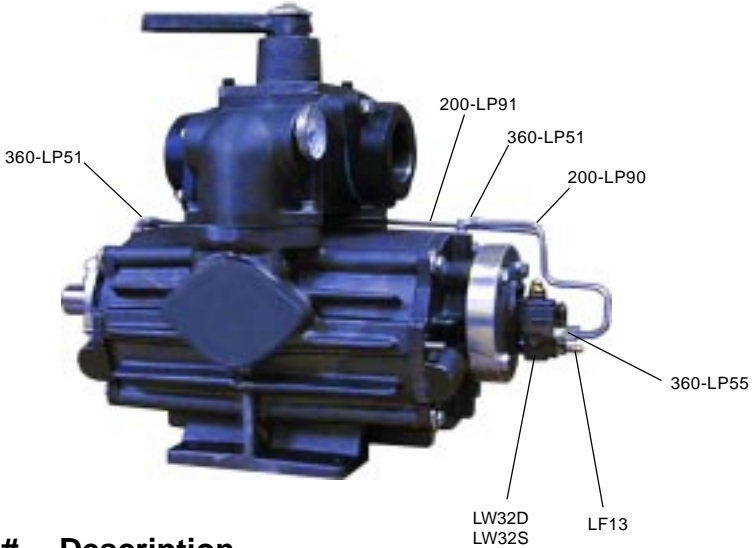

Part #	Description
---------------	--------------------

360-LP51	Fitting
360-LP55	Fitting
200-LP90	Oil Line 10"
200-LP91	Oil Line 24"
LF8	Drive Tab
LF13	Fitting
LW32D	Oil Pump (Clockwise)
LW32S	Oil Pump (Counterclockwise)
P2CW	Pump Body (Clockwise)
P2CCW	Pump Body (Counterclockwise)
P5	Driven Gear (Clockwise)
PA5	Driven Gear (Counterclockwise)
P6	Spring
P7	Driving Gear (Clockwise)
Parts List continued	P7CCW Driving Gear (Counterclockwise)

Oil Pump Detail – Two -Outlet Type
LW32D Clockwise
LW32S Counterclockwise

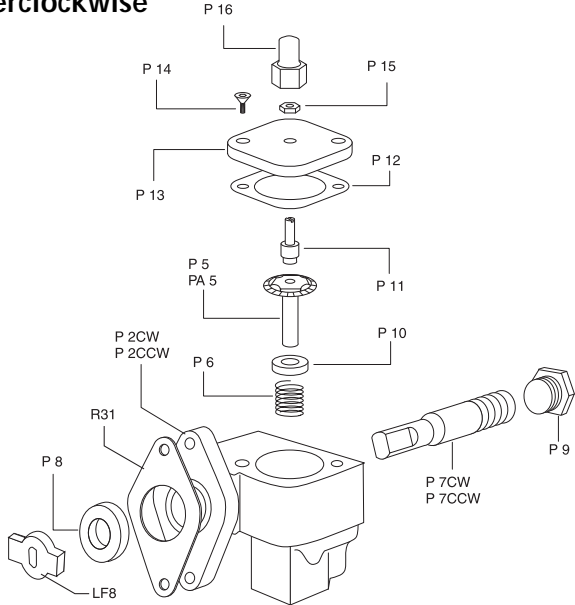

Parts List continued

Part # Description

P 8	Seal
P 9	Plug
P 10	Retainer
P 11	Adjusting Screw
P 12	Gasket
P 13	Lid
P 14	Screw
P 15	Jam Nut
P 16	Cap
R 31	Gasket